

Gear Reduction, Gas Engine Models

1" or 1-1/8" Hollow Shaft, SAE J609-B Flange. 2.2:1 Gear Reduction
Gear Reduction Drive

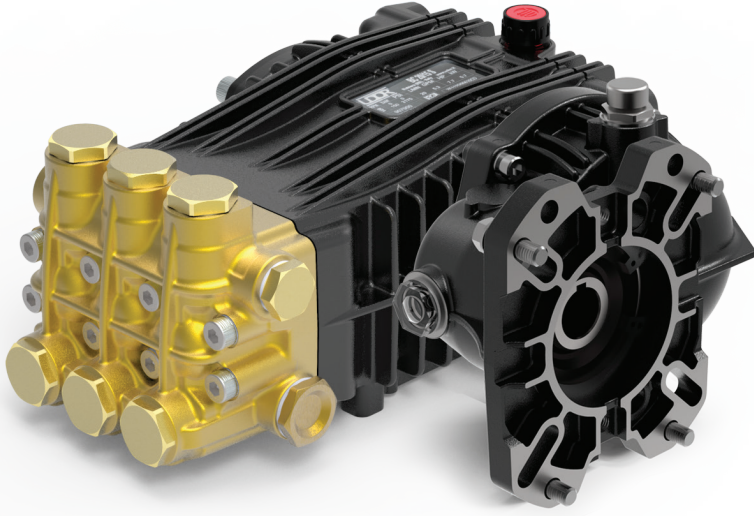

- Heavy Duty Brass Manifold with External and Internal Bracing
- Heavy Duty Bronze or High Strength Aluminum Alloy Connecting Rods.
- Large Diameter Brass Valve Caps with Increased Thread Depth
- Reinforcing Ring on Inlet and Discharge Ports
- Deeper Back Cover for Increased Oil Capacity
- 15.4 oz. Capacity Vented Oil Bath Crank Case
- 1/2" BSP-F Inlet. 3/8" BSP-F Outlet
- Max Fluid Temp, 160°F

BKC Series Gas Engine, Gear Reduction Drive Plunger Pumps

BKC Series super duty plunger pumps include a wide range of models with flow rates from 3.4 to 5.5 GPM and pressures up to 4350 PSI.

Other drive options include 24mm solid shaft, gas engine flange and hydraulic motor flange.

Applications include general pressure cleaning, sewer jetting, vehicle wash equipment and UHP fire fighting applications.

	Model	Flow		Pressure		Plunger Dia.	Crankshaft		Power	Seal Kit	Valve Kit	Wt.
		GPM	l/min	PSI	bar		Stroke	Code				
Gear Reduction	BKC 13/30 GR	3.4	13.0	4350	300	15mm	18.0mm	9	14.5 HP Gas	6061.B2	6061.30	30 lbs
	BKC 15/30 GR	4.0	15.0	4350	300	18mm	14.5mm	I	16 HP Gas	6061.28	6061.30	30 lbs
	BKC 18/25 GR	4.9	18.5	3625	250	18mm	18.0mm	9	16 HP Gas	6061.28	6061.30	30 lbs
	BKC 21/25 GR	5.5	21.0	3625	250	18mm	19.0mm	Y	18 HP Gas	6061.28	6061.30	30 lbs

NOTE: All models available with 1" or 1-1/8" Hollow Shafts . Specify size when ordering (ex. BKC 13/30 GR1 or BKC 13/30 GR1-1/8.)



MAX FLOW
MAX PRESSURE
RATED PUMP SPEED
POWER REQUIREMENT
LUBRICATION

3.4 GPM / 13.0 L/MIN
4350 PSI / 300 BAR
1450 RPM
16.0 HP GAS
15.4 OZ UDOR LUBE

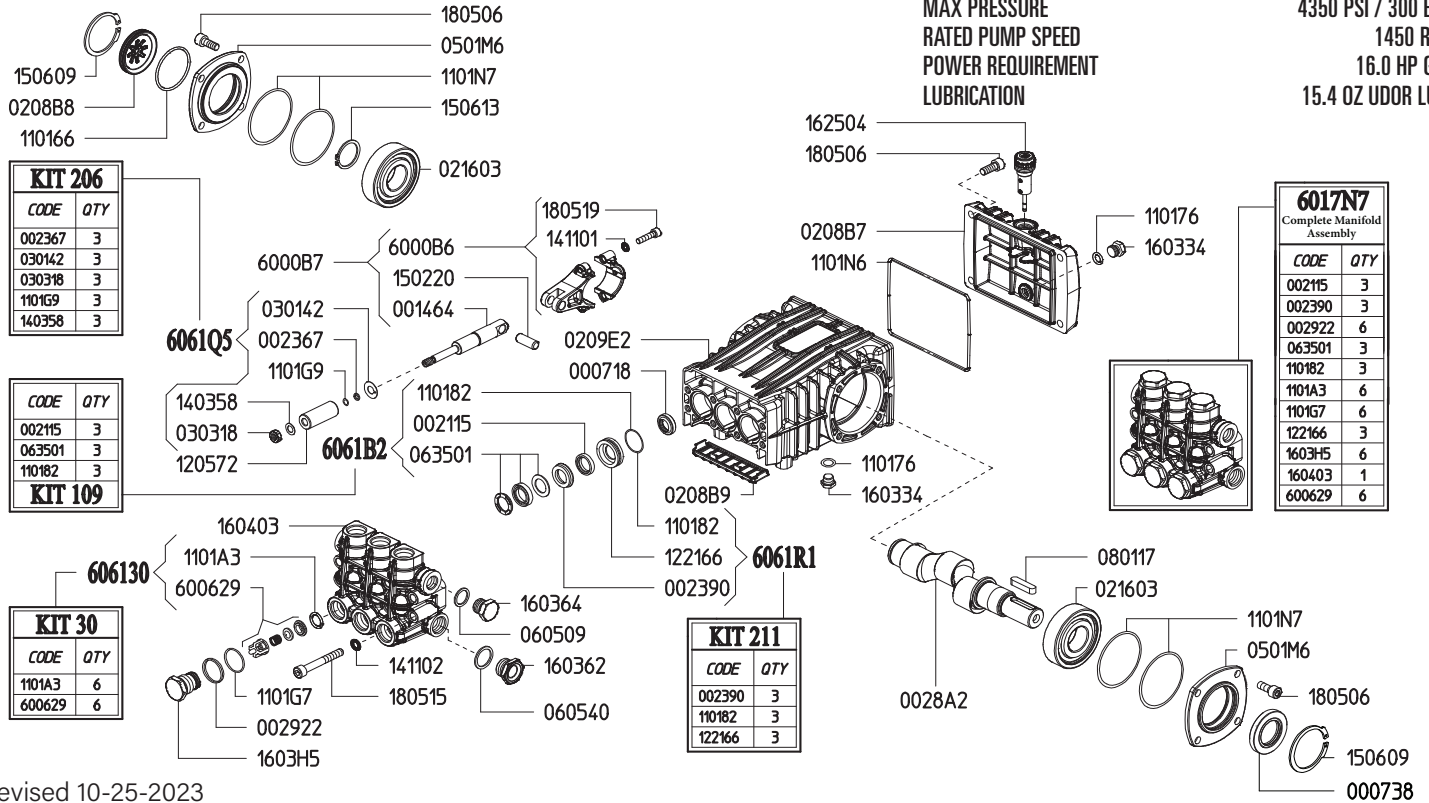

Revised 10-25-2023

Part #	Description	Qty	Part #	Description	Qty
0007.18	OIL SEAL D15X24X5	3	1205.72	CERAMIC PLUNGER D15 "B/BK"	3
0007.38	OIL SEAL D30	1	1221.66	PRESSURE RING D15 "B/BK" ^{D E}	3
0014.64	PLUNGER GUIDE "B/BK"	3	1403.58	WASHER D8 ^C	3
0021.15	WATER SEAL LP D15 ^{B E}	3	1411.01	SERATED WASHER D6	6
0023.67	RING D5.2X8X1.3 ^C	3	1411.02	SERATED WASHER D8	8
0023.90	UPPER RING D15 "B/BK" ^{D E}	3	1502.20	PIN D10X27	3
0028.A2	MALE SHAFT "B/BK" D24	1	1506.09	SNAP RING D52	2
0029.22	RING "CK" D15.2 ^E	6	1506.13	SNAP RING D30	1
0208.B7	BACK COVER "B/BK"	1	1603.34	PLUG G1/4	2
0208.B8	OIL SIGHT GLASS	1	1603.62	PLUG G1/2	1
0208.B9	COVER "B/BK"	1	1603.64	PLUG G3/8	1
0209.E2	CRANKCASE "B-X/BK-X"	1	1603.H5	VALVE PLUG "BK" ^E	6
0216.03	BEARING D30	2	1604.03	HEAD "BK-X" ^E	1
0301.42	SLINGER RING ^C	3	1625.04	OIL PLUG G3/8	1
0303.18	NUT M8XH5 ^C	3	1805.06	ALLEN BOLT M8X20	12
0501.M6	BEARING FLANGE "B/BK"	2	1805.15	ALLEN BOLT M8X60	8
0605.09	GASKET D17X23X1.5	1	1805.19	ALLEN BOLT M6X25	6
0605.40	GASKET D21.5X27X1.5	1	6000.B6	ROD ASSEMBLY "B/BK"	3
0635.01	HIGH PRESSURE SEAL KIT D15 ^{B E}	3	6006.29	VALVE ASSEMBLY WITHOUT O-RING ^{A E}	6
0801.17	KEY A8X7X35	1	6017.N7	COMPLETE MANIFOLD ASSEMBLY	1
1101.66	O-RING - OIL SIGHT GLASS	1	6061.30	KIT 30 - VALVE KIT "BK"	1
1101.76	O-RING - PLUG	2	6061.B2	KIT 109 - WATER SEAL KIT	1
1101.82	O-RING - PRESSURE RING ^{B D E}	3	6061.Q5	KIT 206 - PLUNGER KIT D15/18 "B/BK"	1
1101.A3	O-RING - VALVE ^{A E}	6	6061.R1	KIT 211 - BRASS RING KIT D18 "B/BK"	1
1101.G7	O-RING - VALVE PLUG ^E	6			
1101.G9	O-RING - PLUNGER ROD ^C	3			
1101.N6	O-RING - REAR COVER	1			
1101.N7	O-RING - BEARING FLANGE	4			

^A Parts in 6061.30 (Kit 30).
^B Parts in 6061.B2 (Kit 109).
^C Parts in 6061.Q5 (Kit 206).
^D Parts in 6061.R1 (Kit 211).
^E Parts in 6017.N7 (Complete Manifold Assembly).

**GAS ENGINE GEAR REDUCTION FOR
B/BK/MS/MWT/C/CS/CWT/CK/CX-SERIES PLUNGER PUMPS
on GAS ENGINES with 1" SHAFTS
REQUIRES 9.0 OZ. 90W GEAR LUBE**

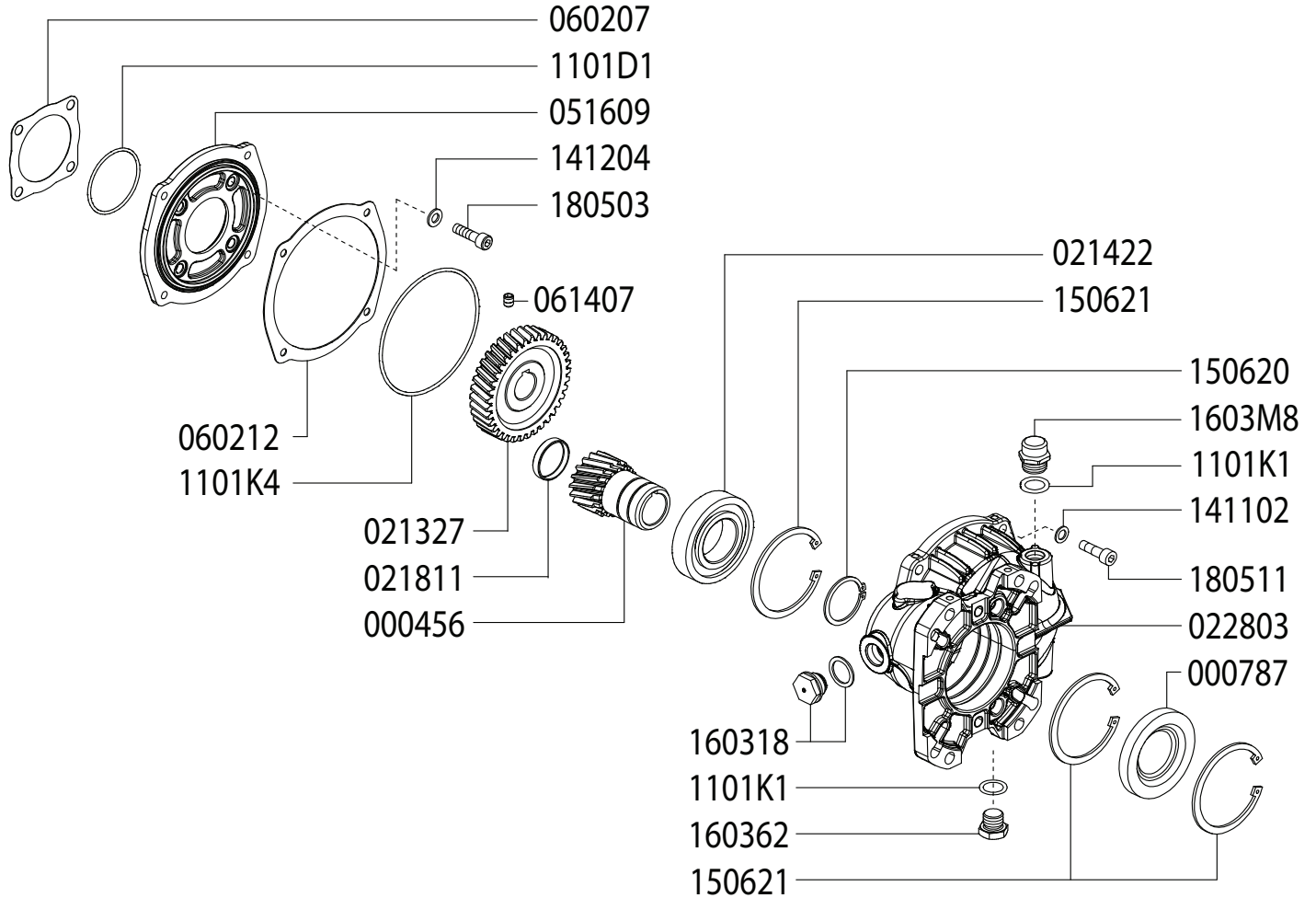

Revised 10-25-2023

Part #	Description	Qty	Part #	Description	Qty
0004.56	GEAR SHAFT "RC122" 1"	1	1101.K4	O-RING - RC122 FLANGE - INSIDE	1
0007.87	SEAL	1	1403.05	WASHER D8,4	4
0213.27	GEAR "RM122" IP	1	1411.02	SERATED WASHER D8	4
0214.22	BALL BEARING D40 "RC122K"	1	1412.04	BONDED WASHER D8.3	4
0218.11	CAP - D37X7	1	1506.20	SNAP RING D40	1
0228.03	COUPLER "RC122"	1	1506.21	SNAP RING D80	3
0516.09	FLANGE "RC122"	1	1603.18	OIL PLUG G1/2 + GASKET	1
0602.07	GASKET "RC122"	1	1603.62	PLUG G1/2	1
0602.12	GASKET "RC122" SPLIT BODY	1	1603.M8	OIL CAP - RC122	1
0614.07	SET SCREW M8X10 UNI5929	1	1805.03	ALLEN SCREW M8X30	4
1101.D1	O-RING - RC122 FLANGE - OUTSIDE	1	1805.11	ALLEN SCREW M8X25	4
1101.K1	O-RING - OIL PLUG / OIL CAP	2			

*Dimensional Drawings are
Shown in Millimeters.
To Convert to Inches,
Multiply Dimension x 0.03937*

BK SERIES PUMPS - 24MM SOLID SHAFT

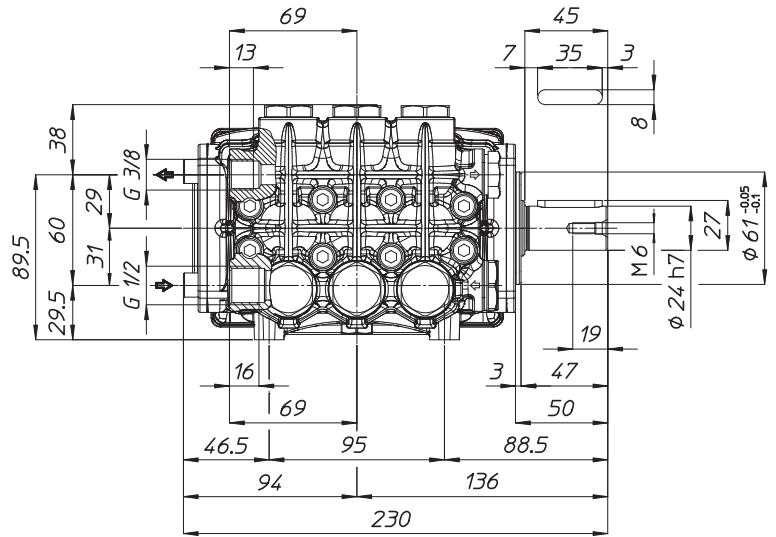
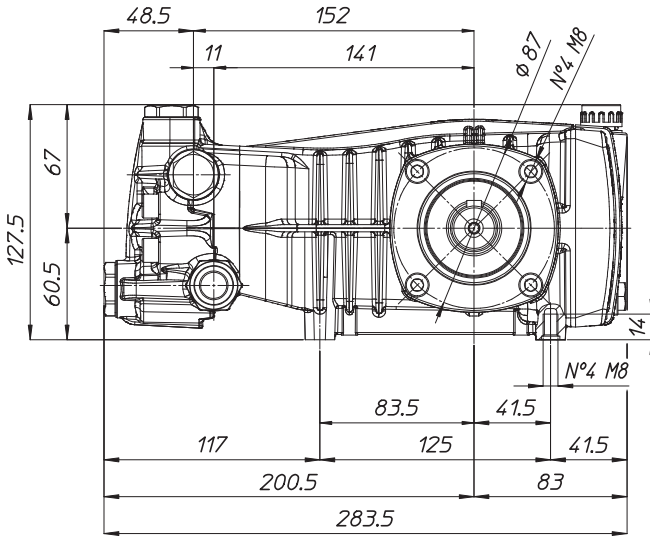

TORQUE SPECS

Ref.	Description	Ft./lb.	Nm	Loctite®
1	Head Bolts	19	25	-
2	Valve Caps	75	100	243
3	Inlet Cap	75	100	243
4	Outlet Cap	60	80	243
5	Bearing Flange Bolts	19	25	-
6	Rear Cover Bolts	19	25	-
7	Connecting Rod Bolts	9	11	243
8	Plunger Bolts	11	15	270
9	Valve Cover Bolts	-	-	-
10	Oil Drain Plug	19	25	-

