

## 6-Cylinder, High-Pressure Diaphragm Pumps with 4900.10 - VRG 260 Regulator



BETA 200 & 240 6-cylinder, high pressure, high volume diaphragm pumps are constructed of anodized aluminum, brass and stainless steel and have anodized aluminum, brass and stainless steel liquid handling parts. Includes mounting rails and 6005.08 control unit with pressure gauge. Simplicity of design and common parts allow for easy and economical maintenance.

BETA 200 & 240 pumps are excellent choices for various horticultural and agricultural spraying applications.

Model	GPM	l/min	PSI	bar	RPM	Drive Configuration	Weight
BETA 200 TS2C	56.0	218.0	725	50	550	1-3/8" 6-Spline Male PTO Thru-Shaft	200 LBS
BETA 240 TS2C	64.0	243.0	725	50	550	1-3/8" 6-Spline Male PTO Thru-Shaft	200 LBS

Specifications	BETA 200	Description	Part #
Inlet Port	(2) 1-1/2" Hose Barb	Diaphragm Kit (GREENTECH)	6062.C7
Outlet Ports	(2) 1/2" Hose Barb, 3/4" NPT	Diaphragm Bolt / Washer Kit	6062.64
Bypass	1-1/4" Hose Barb	Valve Kit	6062.E2
Piston Diameter	75mm	Regulator Repair Kit	8701.03
Crankshaft Stroke/Code	19.0mm / U	Complete Repair Kit	8700.55CK
Dimensions	16.1"L x 15.3"W x 19.7"H		

**Lubrication:** Requires 170 oz. of Udor Lube 40W Premium Pump Oil.  
Alternate Oil: 30W non-detergent or 15W-40 non-detergent oil.



Maximum Flow	56.0 GPM / 218 lpm
Maximum Pressure	725 PSI / 50 bar
Maximum RPM	550 RPM
Inlet Port	(2) 1-1/2" Hose Barb
Outlet Ports	(2) 1/2" Hose Barb Valve, 3/4" FPT
Bypass	1-1/2" Hose Barb
Dimensions	16.1"L x 15.3"W x 19.7"H
Weight	200 lbs

**Lubrication:** Requires 160 oz. of Udor Lube 40W Premium Pump Oil.  
 Alternate Oil: 30W non-detergent or 15W-40 non-detergent oil.

8700.55CK		6062C7 KIT 631		6062E2 KIT 644		606264 KIT 563	
CODE	QTY	CODE	QTY	CODE	QTY	CODE	QTY
010201	6	090362	6	110101	12	010201	6
030103	6	110101	12	600697	12	030103	6
090362	6						
110101	12						
110177	1						
6063E2	12						

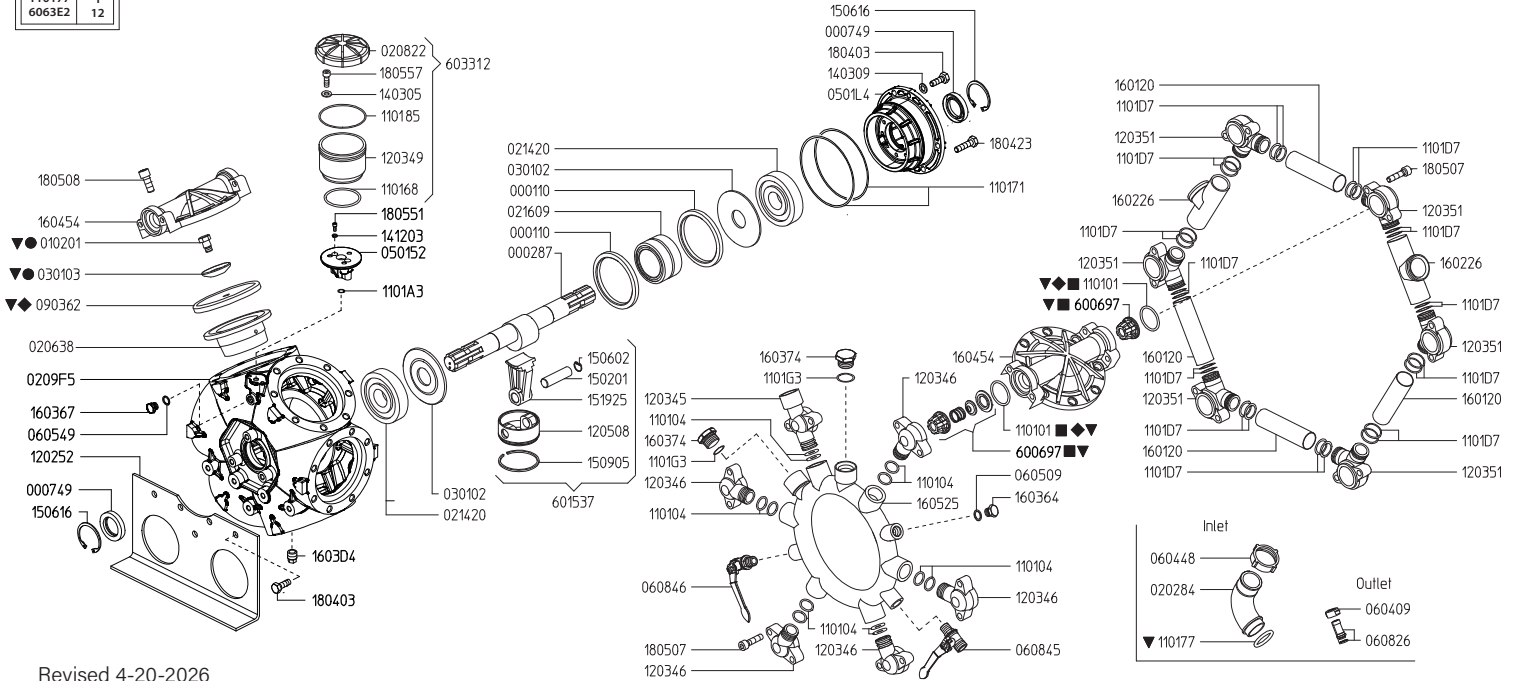

Revised 4-20-2026

Part #	Description	Qty	Part #	Description	Qty
0001.10	RETAINER RING "ZETA 200/300/400"	2	1203.51	INLET ELBOW "BETA 200/240"	6
0002.87	CRANKSHAFT TS 2C	1	1205.08	ALUMINIUM PISTON D75 "BETA/OMEGA/ZETA"	6
0007.49	OIL SEAL D35	2	1403.05	WASHER M8	3
0102.01	DIAPHRAGM BOLT "ZETA/KAPPA 121" ●▼	6	1403.09	WASHER M10	4
0202.84	HOSE BARB D40	2	1412.03	BONDED WASHER D6.7	2
0206.38	SLEEVE D75	6	1502.01	PIN D18X64	6
0208.22	OIL RESERVOIR COVER	1	1506.02	SNAP RING D18	6
0209.F5	CRANKCASE "BETA 200/240"	1	1506.16	SNAP RING D55	2
0214.20	BALL BEARING D35	2	1509.05	PISTON RING D75	6
0216.09	ROLLER BEARING D55	1	1519.25	CONNECTING ROD "ZETA 350/400/BETA 200"	6
0301.02	ROD DISC "BETA/OMEGA"	2	1601.20	SUCTION MANIFOLD "BETA 200/240"	4
0301.03	DIAPHRAGM DISC "BETA/OMEGA" ●▼	6	1602.26	SUCTION MANIFOLD M48X2 "BETA 200/240"	2
0501.52	OIL CUP SUPPORT FLANGE "BETA 200/240"	1	1603.44	PLUG G3/8	1
0501.L4	BUSHING FLANGE "BETA/OMEGA"	1	1603.64	PLUG G3/8	1
0604.09	BRASS NUT G1/2	3	1603.67	PLUG G1/4	1
0604.48	BRASS NUT M48X2	1	1603.74	PLUG G3/4	2
0605.09	GASKET D17	1	1604.54	HEAD "BETA 110/150/200/240"	6
0605.49	GASKET D13	1	1605.25	OUTLET MANIFOLD "BETA 200/240"	1
0608.26	HOSE BARB D13+GASKET	3	1804.03	HEX BOLT M10X30	12
0608.45	BALL VALVE RIGHT	2	1804.23	HEX BOLT M10X40	2
0608.46	BALL VALVE LEFT	1	1805.07	ALLEN BOLT M10X40	24
0903.62	PISTON DIAPHRAGM GREENTECH 130MM ▼	6	1805.08	ALLEN BOLT M12X30	48
1101.01	O-RING - VALVE ◆■▼	12	1805.51	ALLEN BOLT M6X40	2
1101.04	O-RING - DISCHARGE ELBOWS	12	1805.57	ALLEN BOLT M8X22	3
1101.68	O-RING - OIL RESERVOIR	1	6006.97	VALVE ASSEMBLY W/O O-RING ■▼	12
1101.71	O-RING - BUSHING FLANGE	2	6015.37	ROD ASSEMBLY D75	6
1101.77	O-RING - INLET HOSE BARB▼	2	6033.12	OIL RESERVOIR ASSEMBLY	1
1101.A3	O-RING - OIL CUP SUPPORT FLANGE	1	6062.64	DIAPHRAGM BOLT / WASHER KIT (KIT 563)	1
1101.85	O-RING - OIL RESERVOIR	1	6062.C7	DIAPHRAGM KIT GREENTECH 130MM (KIT 631)	1
1101.D7	O-RING - INLET ELBOWS / TUBES	24	6062.E2	IN/OUTLET VALVE KIT (KIT 644)	1
1101.G3	O-RING - PLUG	2	8700.55CK	COMPLETE REPAIR KIT	1
1202.52	BASE PLATE "BETA 200/240"	2			
1203.45	OUTLET ELBOW "BETA"	1			
1203.46	OUTLET ELBOW "BETA"	5			
1203.49	OIL RESERVOIR	1			

- Parts in 6062.64 (Kit 563)
- ◆ Parts in 6062.C7 (Kit 631)
- Parts in 6062.E2 (Kit 644)
- ▼ Parts in 8700.55CK (Complete Repair Kit)

## Adjustable Pressure Regulator

Maximum Flow	66.0 GPM / 250 lpm
Maximum Pressure	1470 PSI /100 bar
Inlet Port	3/4" Male BSP
Outlet Ports	-
Bypass - Hose Barb	1-1/2" HB

<b>606254</b>	
<b>KIT 553</b>	
■	
<i>CODE</i>	<i>QTY</i>
090325	1
110101	1
110131	1
120413	1
150113	1
181001	1

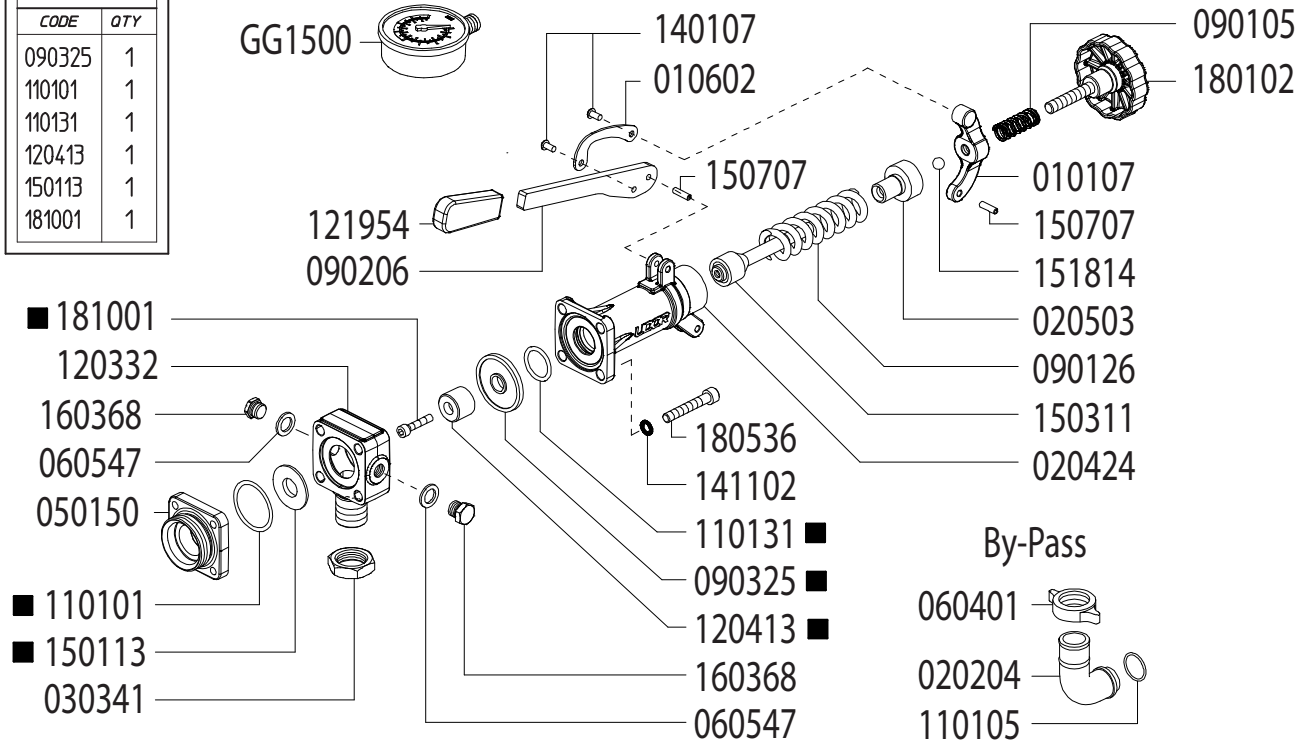

Revised 10-9-2025

Part #	Description	Qty
0101.07	LEVER GUIDE	1
0106.02	PRESSURE BAIL	1
0202.84	1-1/2" BRASS ELBOW HOSE BARB	1
0204.24	VALVE BODY	1
0205.03	VALVE CYLINDER	1
0303.41	NUT	1
0501.50	FLANGE	1
0604.01	BARB NUT	1
0605.47	GASKET D8	1
0901.05	SPRING	1
0901.26	SPRING	1
0902.06	HANDLE	1
0903.25	DIAPHRAGM	1
1101.01	O-RING - BYPASS FLANGE	1
1101.31	O-RING - VALVE BODY	1
1101.77	O-RING - BYPASS HOSE BARB	1
1203.32	INLET ELBOW - 3/4" MALE BSP	1

Part #	Description	Qty
1204.13	POPPET	1
1219.54	HANDLE COVER - RUBBER	1
1401.07	RIVET	2
1411.02	WASHER	4
1501.13	SEAT	1
1503.11	REGULATOR STEM	1
1507.07	PIN	2
1518.14	BALL	1
1603.68	PLUG - 1/4" BRASS	1
1801.02	ADJUSTMENT KNOB	1
1805.36	BOLT	4
1810.01	BOLT - STAINLESS STEEL	1
GG1500	HIGH PRESSURE GAUGE (OPTIONAL)	1
6062.54	REPAIR KIT (KIT 553)	

■ Parts Included in Repair Kit #6062.54 (KIT 553)

### OPERATING INSTRUCTIONS

1. Before operating or re-operating pump, lift R.V. Handle (0902.05) so pump will start at zero pressure.  
**FAILURE TO DO SO WILL VOID PUMP WARRANTY.**
2. Turn Pressure Adjustment Knob (1801.02) counter-clockwise to relieve spring tension. (Step 2 is only necessary on initial start-up and is not necessary for daily operation.)
3. Start unit and let run until air is evacuated from system, when only liquid is expelled from the bypass line.
4. Return R.V. Handle (0902.05) to down position. Open spray gun or spray boom and turn adjustment knob (1801.02) clockwise until desired operating pressure is achieved.

# BETA 200/240 DIMENSIONS

All Dimensions are WITHOUT Control Unit or Regulator

Dimensional Drawings are Shown in Millimeters. To Convert to Inches, Multiply Dimension x 0.03937

## Specifications

BETA 200 BETA 240

Inlet Port - Hose Barb	(2) 1-1/2" HB
Outlet Ports - Hose Barb	(2) 1/2" HB, 3/4" NPT
Bypass - Hose Barb	1-1/4" HB
Dimensions	16.1"L x 15.3"W x 19.7"H
Diaphragm Material	GREENTECH (Standard)

**Lubrication:** Requires 170 oz. of Udor Lube 40W Premium Pump Oil.  
Alternate Oil: 30W non-detergent or 15W-40 non-detergent oil.

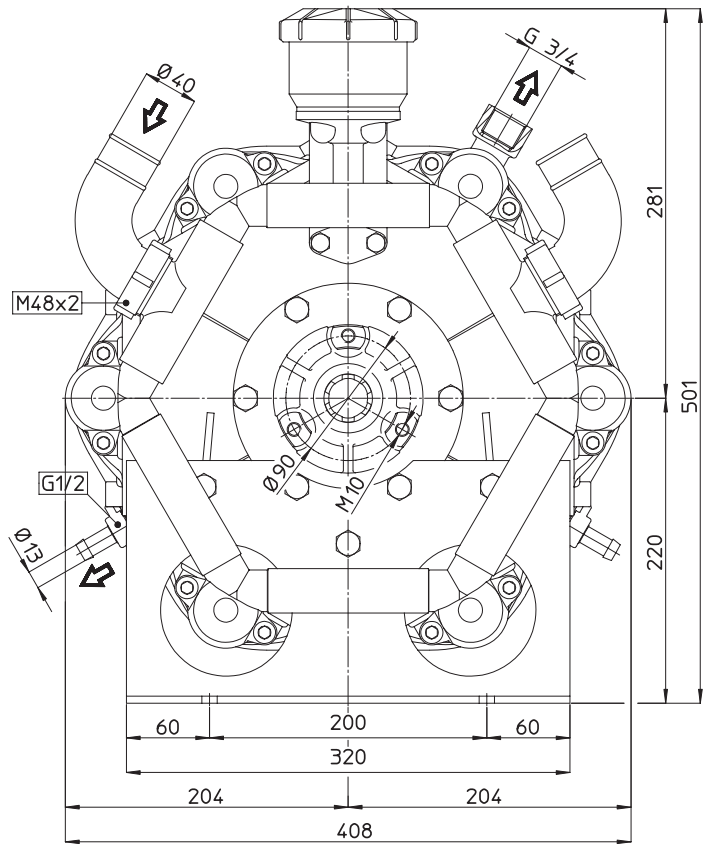
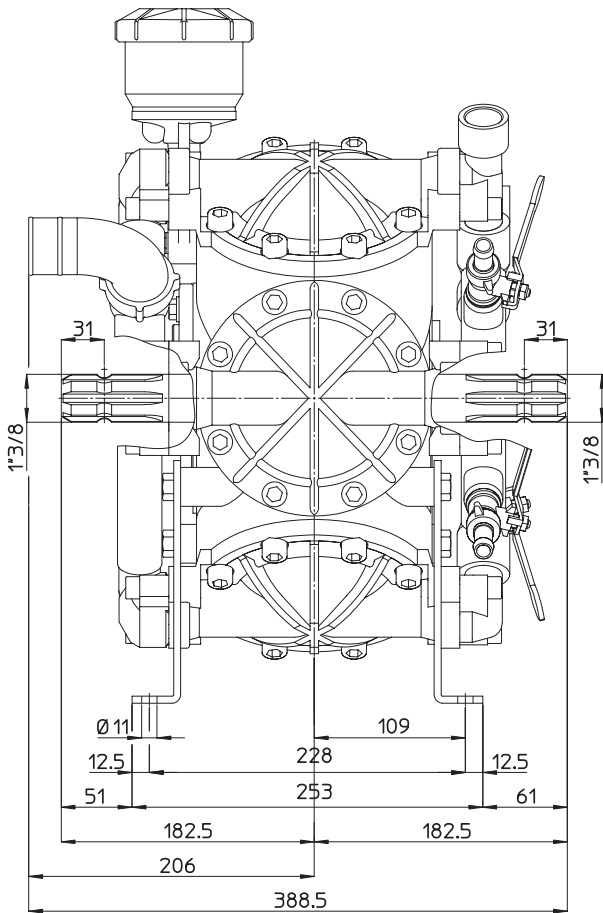

## TORQUE SPECS

Ref.	Description	Ft./lb.	Nm
1	Diaphragm Bolts (Use Loctite 243)	22	30
2	Head Bolts	37	50
3	Pulsation Dampener Bolts	20	28
4	Bearing Flange Bolts	25	34
5	Oil Cup Bolts	7	10
6	Manifold Bolts - Aluminum/Brass	22	30

