

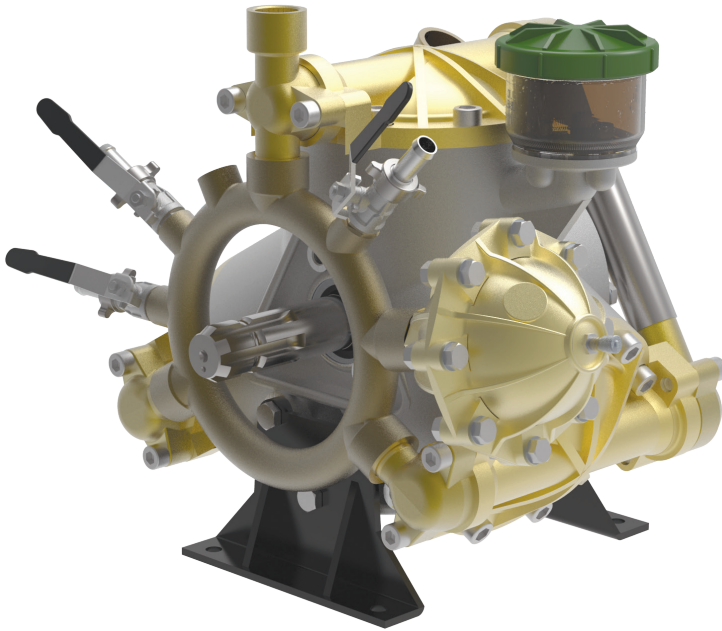

# BETA 130

## 3-Cylinder, High-Pressure Diaphragm Pumps



BETA 130 3-cylinder, high pressure, high volume diaphragm pumps are constructed of anodized aluminum, brass and stainless steel and have anodized aluminum, brass and stainless steel liquid handling parts. Includes mounting rails and 6005.05 control unit with pressure gauge. Simplicity of design and common parts allow for easy and economical maintenance.

BETA 130 pumps are excellent choices for various horticultural and agricultural spraying applications.

Model	GPM	l/min	PSI	bar	RPM	Drive Configuration	Weight
BETA 130 TS2C	34.0	128.0	725	50	550	1-3/8" 6-Spline Male PTO Thru-Shaft	120 LBS

Specifications	BETA 130	Description	Part #
Inlet Port	1-1/2" Hose Barb	Diaphragm Kit (GREENTECH)	8700.06
Outlet Ports	(3) 3/4" Hose Barb	Diaphragm Bolt / Washer Kit	6062.60
Bypass	1" Hose Barb	Valve Kit	6062.D9
Piston Diameter	75mm	Regulator Repair Kit	8701.03
Crankshaft Stroke/Code	19.0mm / U	Complete Repair Kit	8700.06CK
Dimensions	16.8"L x 14.9"W x 17.2"H		

**Lubrication:** Requires 81 oz. of Udor Lube 40W Premium Pump Oil.  
Alternate Oil: 30W non-detergent or 15W-40 non-detergent oil.



6180 140th Avenue NW  
Ramsey, MN 55303

Ph: 651-785-0666  
Fax: 800-732-2670

www.udorusa.com  
www.boominator.com  
info@udorusa.com



Scan this QR Code  
for More Information



**B130  
2024A**

Maximum Flow	34.0 GPM / 126 lpm
Maximum Pressure	725 PSI / 50 bar
Maximum RPM	550 RPM
Inlet Port	1-1/2" Hose Barb
Outlet Ports	(2) 1/2" Hose Barb Valve, 3/4" FPT
Bypass	1" Hose Barb
Dimensions	16.8"L x 14.9"W x 17.2"H
Weight	120 lbs

**Lubrication:** Requires 84 oz. of Udor Lube 40W Premium Pump Oil.  
Alternate Oil: 30W non-detergent or 15W-40 non-detergent oil.

8700.06CK		870006 KIT 627		606257 KIT 556		6062D9 KIT 642		606260 KIT 559	
CODE	QTY	CODE	QTY	CODE	QTY	CODE	QTY	CODE	QTY
010201	3	090316	1	090301	3	110101	6	010201	3
030103	3	090362	3	090316	1	600697	6	030103	3
090362	3	110101	6	110101	6				
110101	6								
110177	1								
6063E2	6								

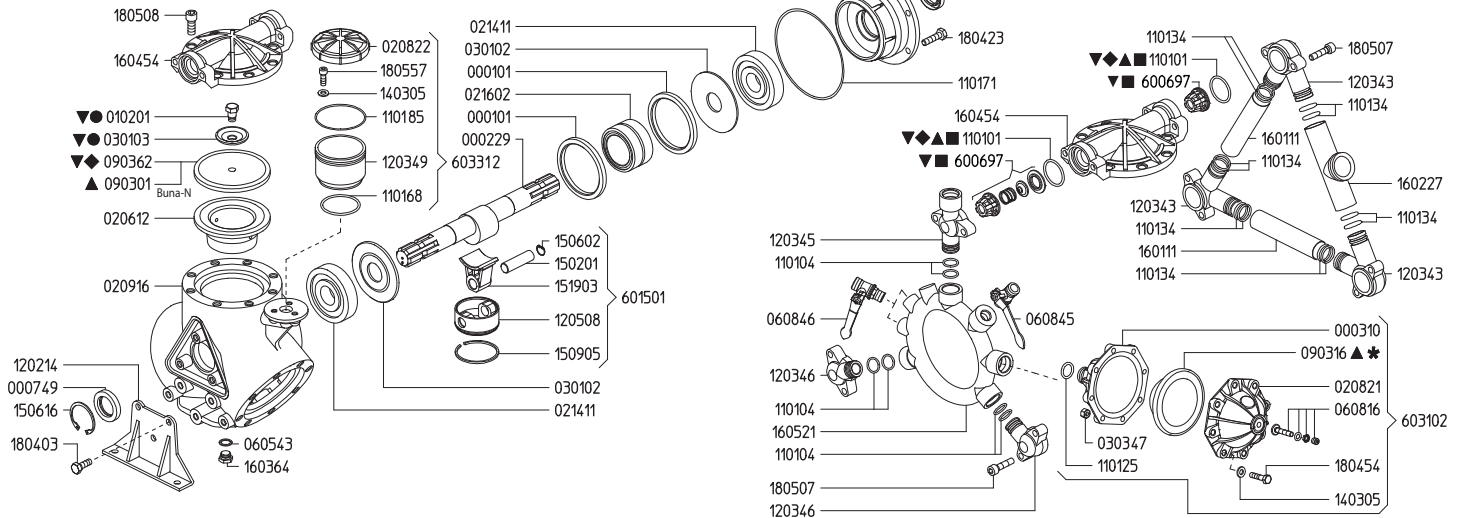
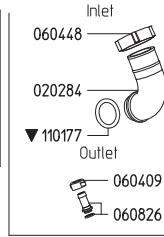

Revised 1-17-2024

Part #	Description	Qty
0001.01	RETAINER RING "BETA/OMEGA"	2
0002.29	CRANKSHAFT - TS 2C	1
0003.10	PRESSURE ACCUMULATOR BASE	1
0007.49	OIL SEAL D35	2
0102.01	DIAPHRAGM BOLT "ZETA/KAPPA 121" ●▼	3
0202.84	HOSE BARB D40	1
0206.12	SLEEVE D75	3
0208.21	PRESSURE ACCUMULATOR COVER	1
0208.22	OIL RESERVOIR COVER	1
0209.16	CRANKCASE "BETA 110"	1
0214.11	BALL BEARING D35	2
0216.02	ROLLER BEARING D55	1
0301.02	ROD DISC "BETA/OMEGA"	2
0301.03	DIAPHRAGM DISC "BETA/OMEGA" ●▼	3
0303.47	HEX NUT M8X8	8
0501.L4	BUSHING FLANGE "BETA/OMEGA"	1
0604.09	BRASS NUT G1/2	1
0604.48	BRASS NUT M48X2	1
0605.43	GASKET D17	1
0608.16	AIR VALVE ASSY	1
0608.26	HOSE BARB D13+GASKET	3
0608.45	BALL VALVE - RIGHT	1
0608.46	BALL VALVE - LEFT	1
0903.01	PISTON DIAPHRAGM BUNA-N 130MM ▲	3
0903.16	ACCUMULATOR DIAPHRAGM ◆▲▲	1
0903.62	PISTON DIAPHRAGM GREENTECH 130MM ◆▼	3
1101.01	O-RING - VALVE ▲◆◆▼	6
1101.04	O-RING - OUTLET ELBOW	6
1101.25	O-RING - PRESSURE ACCUMULATOR	1
1101.34	O-RING - DISCHARGE MANIFOLD TUBES	12
1101.68	O-RING - OIL RESERVOIR	1
1101.71	O-RING - BUSHING FLANGE	1
1101.77	O-RING - INLET HOSE BARB▼	1
1101.85	O-RING - OIL RESERVOIR	1
1202.14	BASE PLATE "BETA 110/150"	2

Part #	Description	Qty
1203.43	INLET ELBOW "BETA 110"	4
1203.46	OUTLET ELBOW "BETA"	2
1203.49	OIL RESERVOIR "BETA"	1
1205.08	ALUMINIUM PISTON D75 "BETA/OMEGA/ZETA"	3
1403.05	WASHER M8	11
1403.09	WASHER M10	4
1502.01	PIN D18X64	3
1506.02	SNAP RING D18	3
1506.16	SNAP RING D55	2
1509.05	PISTON RING D75	3
1519.03	CONNECTING ROD "OMEGA/BETA 110/150"	3
1601.11	SUCTION MANIFOLD "BETA 110"	2
1602.27	SUCTION MANIFOLD M48X2 "BETA 110"	1
1603.64	PLUG G3/8	1
1604.54	HEAD "BETA 110/150/200/240"	3
1605.21	OUTLET MANIFOLD "BETA 110"	1
1804.03	HEX BOLT M10X30	10
1804.54	HEX BOLT M8X35	8
1805.07	ALLEN BOLT M10X40	12
1805.57	ALLEN BOLT M8X22	3
1805.08	ALLEN BOLT M12X30	24
6006.97	VALVE ASSEMBLY W/O O-RING ■▼	6
6015.01	ROD ASSEMBLY "OMEGA/BETA" D75	3
6031.02	PRESSURE ACCUMULATOR ASSY "BETA"	1
6033.12	OIL RESERVOIR ASSY "BETA"	1
6062.57	DIAPHRAGM KIT BUNA-N 130MM (KIT 556)	1
6062.60	DIAPHRAGM DISC "BETA 110" (KIT 559)	1
6062.D9	IN/OUTLET VALVE KIT "BETA 110" (KIT 642)	1
8700.06	DIAPHRAGM KIT GREENTECH 130MM (KIT 627)	1
8700.06CK	COMPLETE REPAIR KIT	1

● Parts in 6062.57 (Kit 556)  
 ■ Parts in 6062.60 (Kit 559)  
 ▲ Parts in 6062.D9 (Kit 642)  
 ◆ Parts in 8700.06 (Kit 627)  
 ▼ Parts in 8700.06 (Complete Repair Kit)

## Adjustable Pressure Regulator

Maximum Flow	47.3 GPM / 179.2 lpm
Maximum Pressure	1200 PSI / 81 bar
Inlet Ports	3/4" Male BSP
Outlet Ports	-
Bypass - Hose Barb	1" HB

<b>606254</b>	
<b>KIT 553</b>	
■	
<i>CODE</i>	<i>QTY</i>
090325	1
110101	1
110131	1
120413	1
150125	1
181001	1

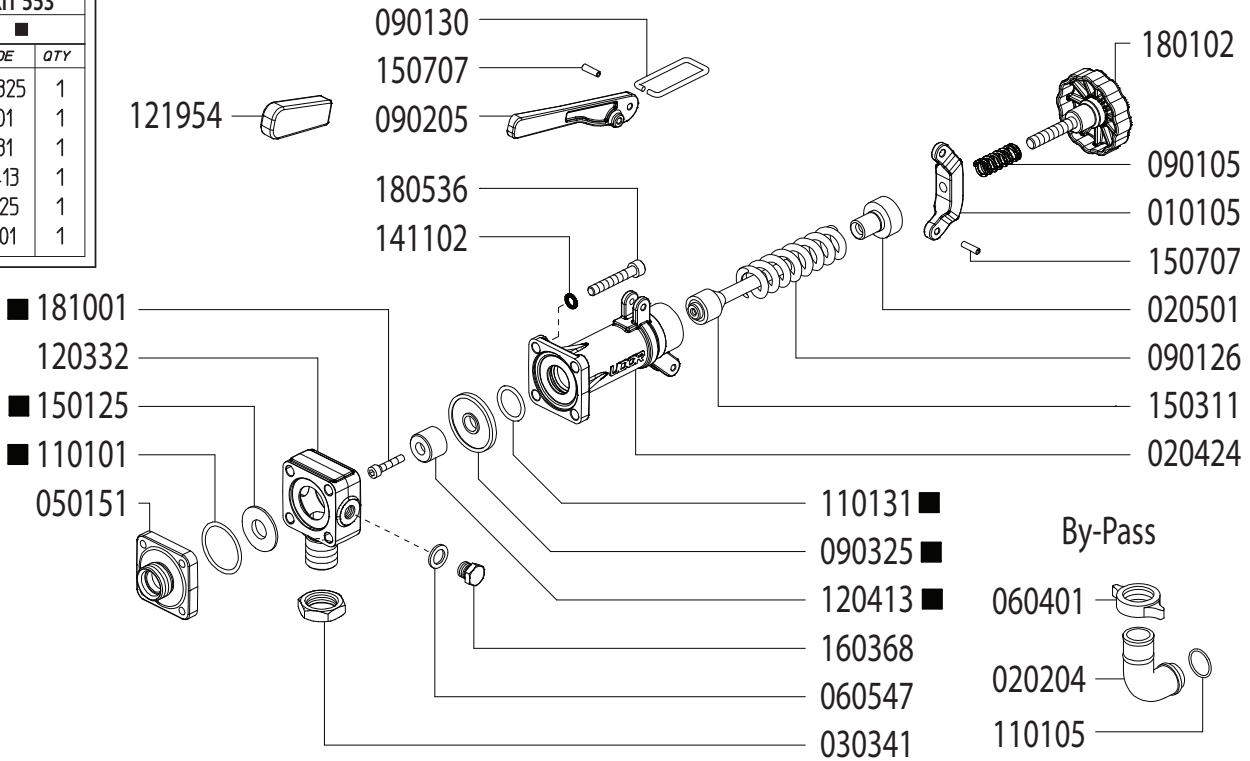

Revised 1-17-2024

Part #	Description	Qty
0101.05	LEVER GUIDE	1
0202.04	1" BRASS ELBOW HOSE BARB	1
0204.24	VALVE BODY	1
0205.01	VALVE CYLINDER	1
0303.41	NUT	1
0501.51	FLANGE	1
0604.01	BARB NUT	1
0901.05	SPRING	1
0901.30	PRESSURE BAIL	1
0901.26	SPRING	1
0902.05	HANDLE	1
0903.25 ■	DIAPHRAGM	1
1101.01 ■	O-RING - BYPASS FLANGE	1
1101.05	O-RING - BYPASS HOSE BARB	1

Part #	Description	Qty
1101.31 ■	O-RING - VALVE BODY	1
1203.32	INLET ELBOW - 3/4" MALE BSP	1
1204.13	POPPET ■	1
1219.54	HANDLE COVER - RUBBER	1
1501.25	SEAT ■	1
1503.11	REGULATOR STEM	1
1507.07	PIN	2
1801.02	ADJUSTMENT KNOB	1
1805.36	BOLT	4
1810.01	BOLT - STAINLESS STEEL ■	1
GG1500	HIGH PRESSURE GAUGE (OPTIONAL)	1
6062.54	REPAIR KIT (KIT 553)	

■ Parts Included in Repair Kit #6062.54 (KIT 553)

### OPERATING INSTRUCTIONS

- Before operating or re-operating pump, lift R.V. Handle (0902.05) so pump will start at zero pressure.  
**FAILURE TO DO SO WILL VOID PUMP WARRANTY.**
- Turn Pressure Adjustment Knob (1801.02) counter-clockwise to relieve spring tension. (Step 2 is only necessary on initial start-up and is not necessary for daily operation.)
- Start unit and let run until air is evacuated from system, when only liquid is expelled from the bypass line.
- Return R.V. Handle (0902.05) to down position. Open spray gun or spray boom and turn adjustment knob (1801.02) clockwise until desired operating pressure is achieved.

All Dimensions are WITHOUT Control Unit or Regulator

Dimensional Drawings are Shown in Millimeters. To Convert to Inches, Multiply Dimension x 0.03937

### Specifications

### BETA 130

Inlet Port - Hose Barb	1-1/2" HB
Outlet Ports - Hose Barb	(3) 3/4" HB
Bypass - Hose Barb	1" HB
Dimensions	16.8"L x 14.9"W x 17.2"H
Diaphragm Material	GREENTECH (Standard)

**Lubrication:** Requires 81 oz. of Udor Lube 40W Premium Pump Oil.  
Alternate Oil: 30W non-detergent or 15W-40 non-detergent oil.

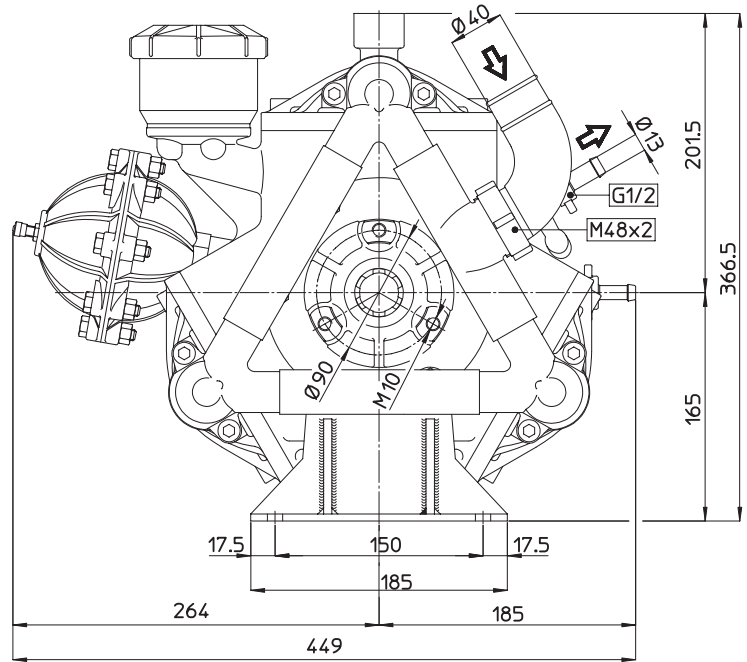
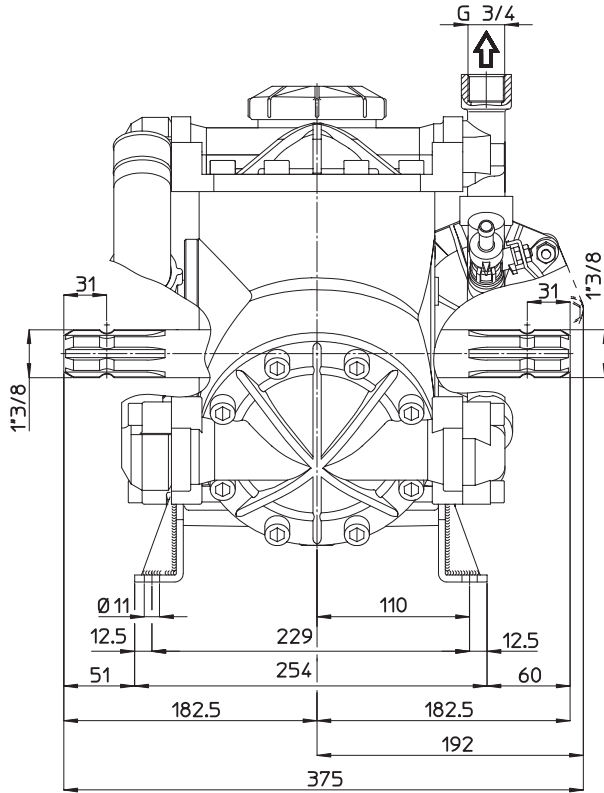

## TORQUE SPECS

Ref.	Description	Ft./lb.	Nm
1	Diaphragm Bolts (Use Loctite 243)	22	30
2	Head Bolts	37	50
3	Pulsation Dampener Bolts	20	28
4	Bearing Flange Bolts	25	34
5	Oil Cup Bolts	7	10
6	Manifold Bolts - Aluminum/Brass	22	30

