

Gear Reduction, Gas Engine Models

1" or 1-1/8" Hollow Shaft, SAE J609-B Flange. 2.2:1 Gear Reduction
Gas Engine Gear Reduction

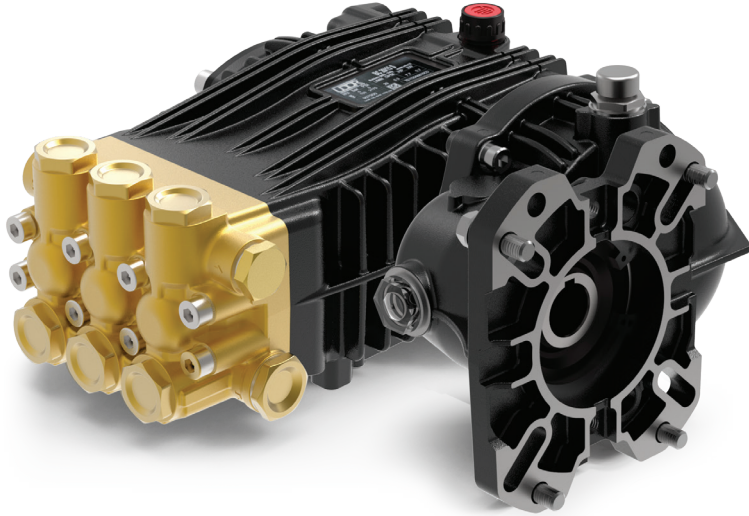

- Brass Manifold
- Heat Treated Crankshaft
- Stainless Steel Piston Guides
- High Strength Aluminum Alloy Connecting Rods
- Industrial Quality Tapered Roller Bearings
- Solid Ceramic Plungers
- Stainless Steel Check Valves
- Heavy Duty Flat Base High Pressure Seals
- Replaceable PTFE Coated Body Guides
- 15.4 oz. Capacity Vented Oil Bath Crank Case
- 1/2" BSP-F Inlet. 3/8" BSP-F Outlet
- Max Fluid Temp, 160°F

BC Series Gas Engine Gear Reduction Plunger Pumps

BC Series standard duty plunger pumps include a wide range of models with flow rates from 3.4 to 5.5 GPM and pressures up to 2900 PSI.

Other drive options include 24mm solid shaft, electric motor flange, gas engine flange and hydraulic motor flange.

Applications include general pressure cleaning, sewer jetting, vehicle wash equipment and fire fighting applications.

	Model	Flow		Pressure		Plunger Dia.	Crankshaft		Power	Seal Kit	Valve Kit	Wt.
		GPM	l/min	PSI	bar		Stroke	Code				
1450 RPM	BC 13/20 GR	3.4	13.0	2900	200	15mm	18.0mm	9	9 HP Gas	6061.B2	6061.02	28 lbs
	BC 15/20 GR	4.0	15.0	2900	200	18mm	14.5mm	I	11 HP Gas	6061.B2	6061.02	28 lbs
	BC 18/20 GR	4.9	18.5	2900	200	18mm	18.0mm	9	14.5 HP Gas	6061.28	6061.02	28 lbs
	BC 21/20 GR	5.5	21.0	2900	200	18mm	19.0mm	Y	16 HP Gas	6061.28	6061.02	28 lbs

NOTE: All pump models available with left-hand drive option. Add 'L' to model number when ordering (ex. BD 5.0/30 UL)



MAX FLOW
MAX PRESSURE
RATED PUMP SPEED
POWER REQUIREMENT
LUBRICATION

4.0 GPM / 15.0 L/MIN
2900 PSI / 200 BAR
1450 RPM
16.0 HP GAS
15.4 OZ UDOR LUBE

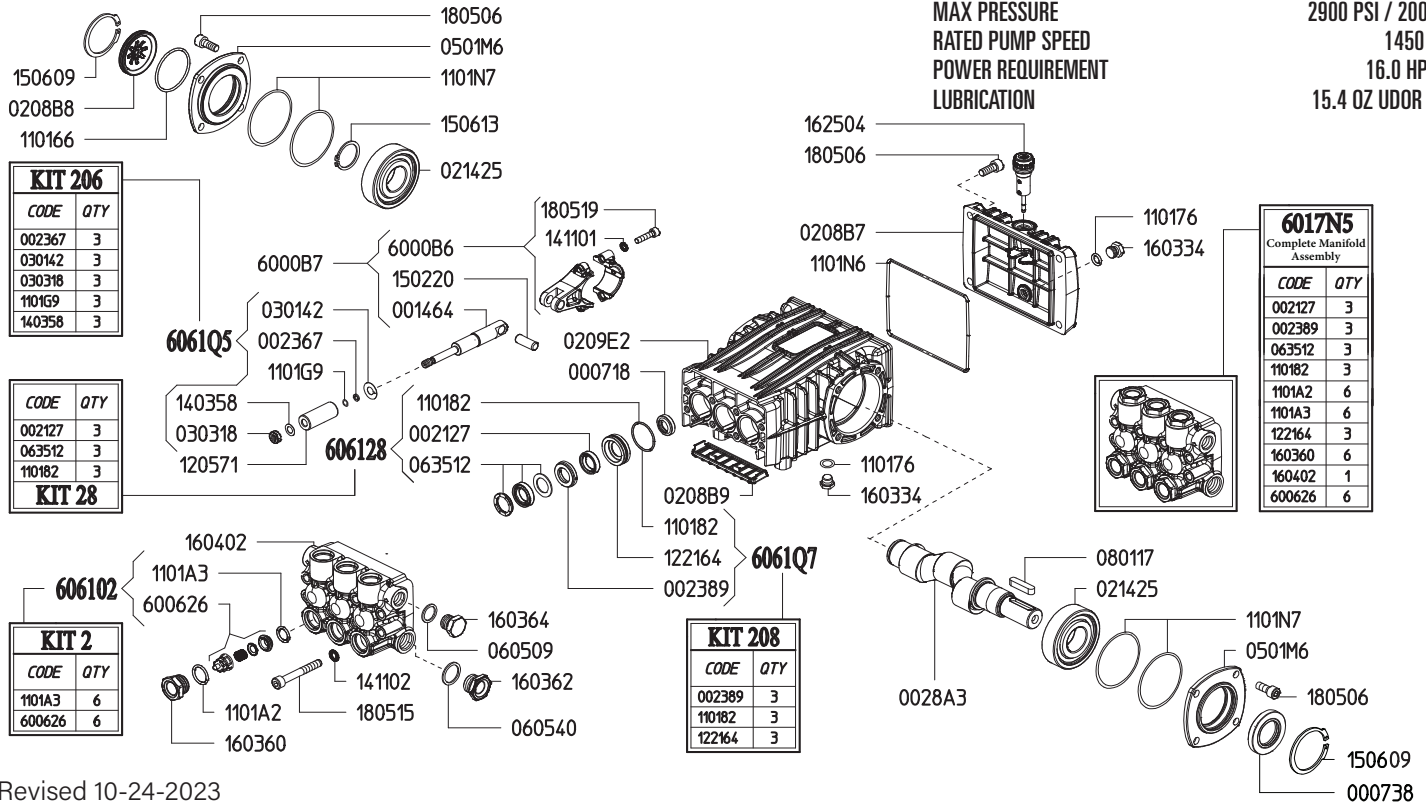

Revised 10-24-2023

Part #	Description	Qty	Part #	Description	Qty
0007.18	OIL SEAL D15X24X5	3	1205.71	CERAMIC PLUNGER D18 "B/BK"	3
0007.38	OIL SEAL D30	1	1221.64	PRESSURE RING D18 "B/BK" ^{D E}	3
0014.64	PLUNGER GUIDE "B/BK"	3	1403.58	WASHER D8 ^C	3
0021.27	WATER SEAL LP D18 ^{B E}	3	1411.01	SERATED WASHER D6	6
0023.67	RING D5.2X8X1.3 ^C	3	1411.02	SERATED WASHER D8	8
0023.89	UPPER RING D18 "B/BK" ^{D E}	3	1502.20	PIN D10X27	3
0028.A3	MALE SHAFT "B/BK" D24	1	1506.09	SNAP RING D52	2
0208.B7	BACK COVER "B/BK"	1	1506.13	SNAP RING D30	1
0208.B8	OIL SIGHT GLASS	1	1603.34	PLUG G1/4	2
0208.B9	COVER "B/BK"	1	1603.60	VALVE PLUG D15/18/20 ^E	6
0209.E2	CRANKCASE "B-X/BK-X"	1	1603.62	PLUG G1/2	1
0214.25	BEARING D30	2	1603.64	PLUG G3/8	1
0301.42	SLINGER RING ^C	3	1604.02	HEAD "B-X" ^E	1
0303.18	NUT M8XH5 ^C	3	1625.04	OIL PLUG G3/8	1
0501.M6	BEARING FLANGE "B/BK"	2	1805.06	ALLEN BOLT M8X20	12
0605.09	GASKET D17X23X1.5	1	1805.15	ALLEN BOLT M8X60	8
0605.40	GASKET D21.5X27X1.5	1	1805.19	ALLEN BOLT M6X25	6
0635.12	HIGH PRESSURE SEAL KIT D18 ^{B E}	3	6000.B6	ROD ASSEMBLY "B/BK"	3
0801.17	KEY A8X7X35	1	6006.26	VALVE ASSEMBLY WITHOUT O-RING ^{A E}	6
1101.66	O-RING - OIL SIGHT GLASS	1	6017.N5	COMPLETE MANIFOLD ASSEMBLY	1
1101.76	O-RING - PLUG	2	6061.02	KIT 2 - VALVE KIT "PK/M/B"	1
1101.82	O-RING - PRESSURE RING ^{B D E}	3	6061.28	KIT 28 - WATER SEAL KIT	1
1101.A2	O-RING - VALVE PLUG ^E	6	6061.Q5	KIT 206 - PLUNGER KIT D15/18 "B/BK"	1
1101.A3	O-RING - VALVE ^{A E}	6	6061.Q7	KIT 208 - BRASS RING KIT D18 "B/BK"	1
1101.G9	O-RING - PLUNGER ROD ^C	3			
1101.N6	O-RING - BACK COVER	1			
1101.N7	O-RING - BEARING FLANGE	4			

A Parts in 6061.02 (Kit 2).
 B Parts in 6061.28 (Kit 28).
 C Parts in 6061.Q5 (Kit 206).
 D Parts in 6061.Q7 (Kit 208).
 E Parts in 6017.N5 (Complete Manifold Assembly).

**GAS ENGINE GEAR REDUCTION FOR
B/BK/MS/MWT/C/CS/CWT/CK/CX-SERIES PLUNGER PUMPS
on GAS ENGINES with 1" SHAFTS
REQUIRES 9.0 OZ. 90W GEAR LUBE**

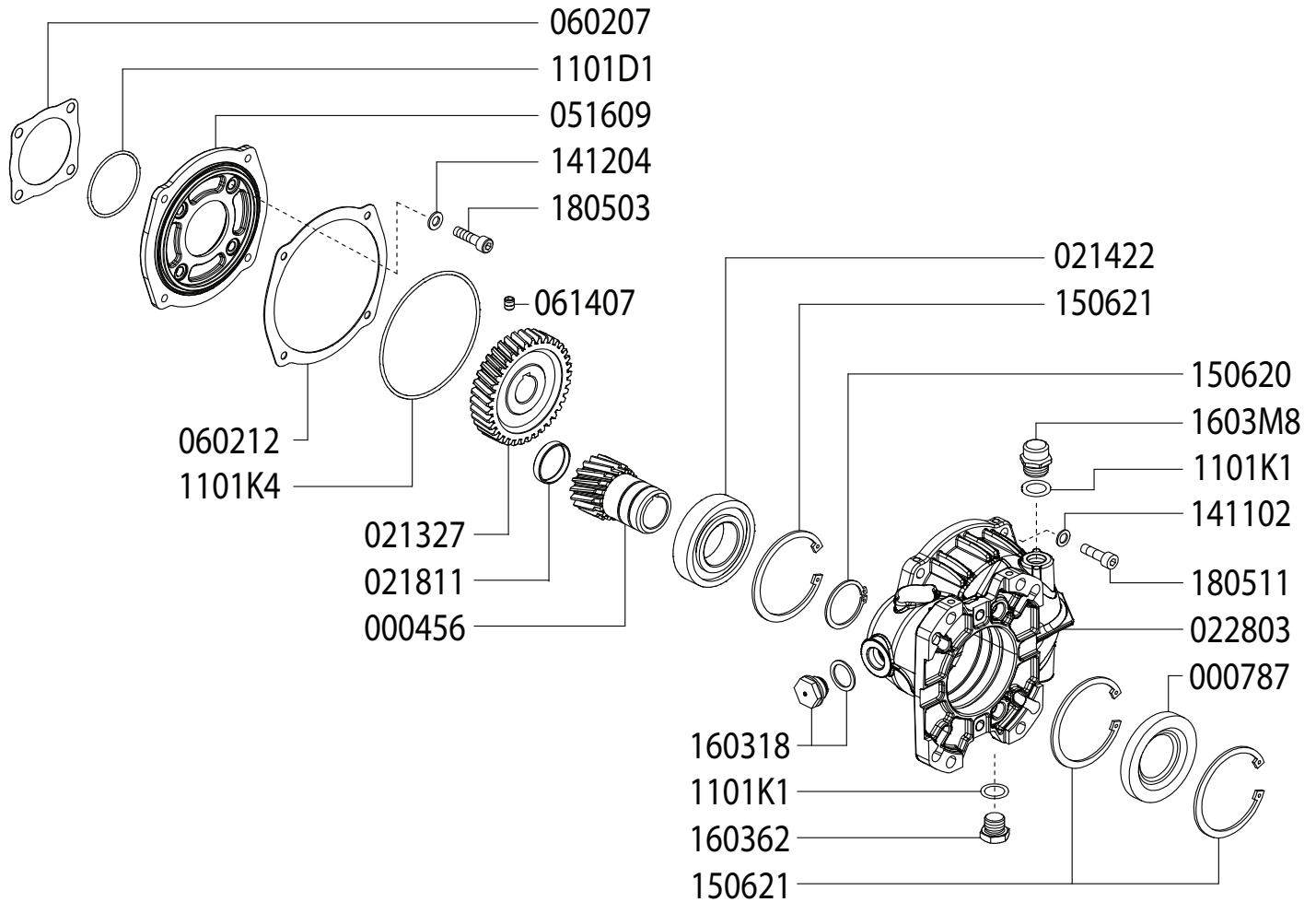

Revised 10-24-2023

Part #	Description	Qty	Part #	Description	Qty
0004.56	GEAR SHAFT "RC122" 1"	1	1101.K4	O-RING - RC122 FLANGE - INSIDE	1
0007.87	SEAL	1	1403.05	WASHER D8,4	4
0213.27	GEAR "RM122" IP	1	1411.02	SERATED WASHER D8	4
0214.22	BALL BEARING D40 "RC122K"	1	1412.04	BONDED WASHER D8.3	4
0218.11	CAP - D37X7	1	1506.20	SNAP RING D40	1
0228.03	COUPLER "RC122"	1	1506.21	SNAP RING D80	3
0516.09	FLANGE "RC122"	1	1603.18	OIL PLUG G1/2 + GASKET	1
0602.07	GASKET "RC122"	1	1603.62	PLUG G1/2	1
0602.12	GASKET "RC122" SPLIT BODY	1	1603.M8	OIL CAP - RC122	1
0614.07	SET SCREW M8X10 UNI5929	1	1805.03	ALLEN SCREW M8X30	4
1101.D1	O-RING - RC122 FLANGE - OUTSIDE	1	1805.11	ALLEN SCREW M8X25	4
1101.K1	O-RING - OIL PLUG / OIL CAP	2			

WEIGHT
LUBRICATION

20 LBS
15.4 OZ UDOR LUBE

*Dimensional Drawings are
Shown in Millimeters.
To Convert to Inches,
Multiply Dimension x 0.03937*

B SERIES PUMPS - 24MM SOLID SHAFT

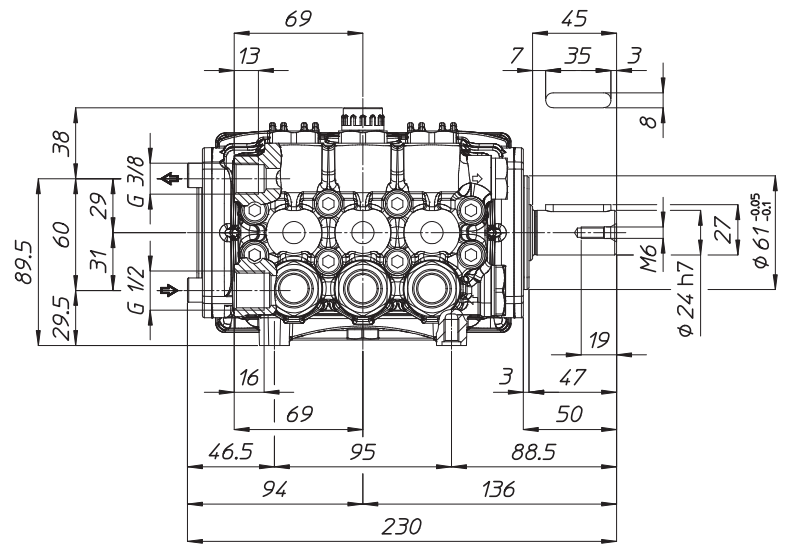
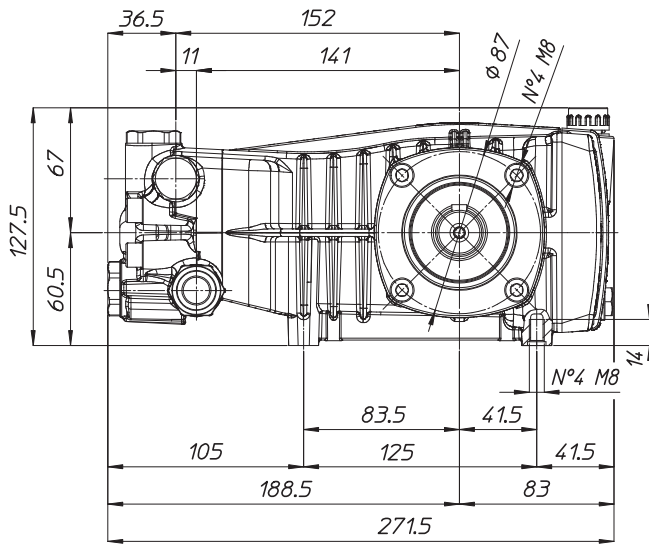

TORQUE SPECS

Ref.	Description	Ft./lb.	Nm	Loctite®
1	Head Bolts	19	25	-
2	Valve Caps	75	100	243
3	Inlet Cap	75	100	243
4	Outlet Cap	60	80	243
5	Bearing Flange Bolts	19	25	-
6	Rear Cover Bolts	19	25	-
7	Connecting Rod Bolts	9	11	243
8	Plunger Bolts	11	15	270
9	Valve Cover Bolts	-	-	-
10	Oil Drain Plug	19	25	-

