

MAX FLOW
MAX PRESSURE
RATED PUMP SPEED
POWER REQUIREMENT
LUBRICATION

4.0 GPM / 15 L/MIN
1450 PSI / 100 BAR
1750 RPM
4.0 HP ELECTRIC
10.25 OZ UDOR LUBE

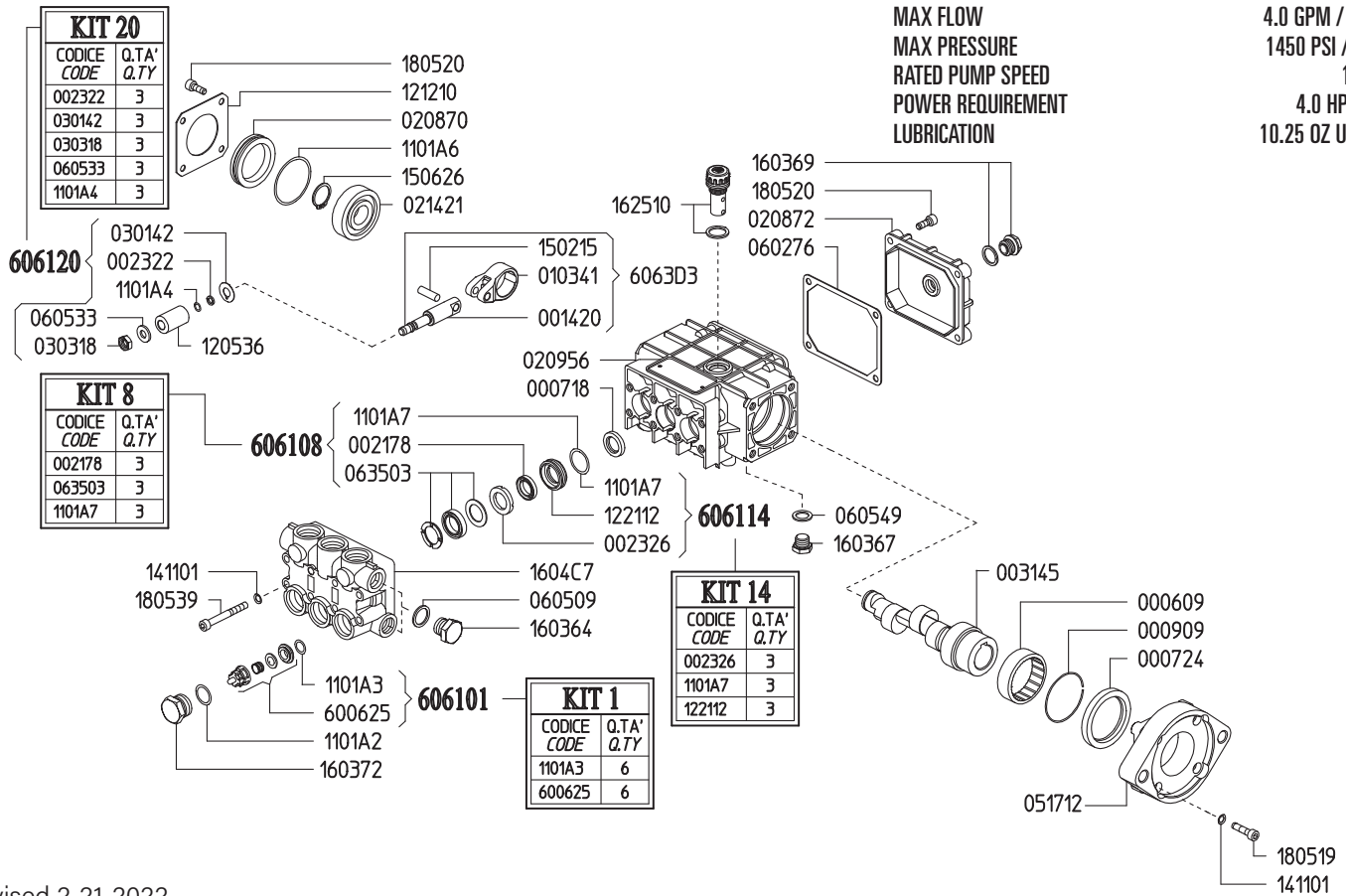

Revised 2-21-2022

Part #	Description	Qty	Part #	Description	Qty
0006.09	BUSHING D45	1	1101.A6	O-RING - BEARING COVER	1
0007.18	OIL SEAL D15X24X5	3	1101.A7	O-RING - LP SEAL RETAINER ^{B C}	3
0007.24	OIL SEAL D40X52X7	1	1205.36	CERAMIC PLUNGER D15X30 "PN"	3
0009.09	ELASTIC RING D52X2.5	1	1212.10	METAL COVER "PN"	1
0014.20	PLUNGER GUIDE D15/18 "PN"	3	1221.12	LOW PRESS. SEAL RETAINER D18 ^C	3
0021.78	WATER SEAL LP. D15 ^B	3	1411.01	SERATED WASHER D6	12
0023.22	RING D6.3X9X1.3 2021 "PN/C/G" ^C	3	1502.15	PIN D7X25.5	3
0023.26	INTERMEDIATE RING D18 "PN" ^C	3	1506.26	SNAP RING D20	1
0031.45	HOLLOW SHAFT "PN" D5/8" ECC=6.25	1	1603.64	PLUG G3/8	1
0103.41	CONNECTING ROD "PN/PS"	3	1603.67	PLUG G1/4	1
0208.70	COVER "PN"	1	1603.69	OIL PLUG G1/4+GASKET	1
0208.72	BACK COVER "PN"	1	1603.72	VALVE PLUG "PN" PISTON D15/18	6
0209.56	CRANKCASE "PN/PS"	1	1604.C7	HEAD "PN" PISTON D15/18 ALUM	1
0214.21	BALL BEARING D20X52X15	1	1625.10	OIL PLUG G3/8 "PN"	1
0301.42	SLINGER RING ^D	3	1805.19	ALLEN BOLT M6X25	4
0303.18	NUT "PN/PK/PKWT/PS M8XH5 ^D	3	1805.20	ALLEN BOLT M6X16	8
0517.12	MOTOR FLANGE "PN" HYD	1	1805.39	ALLEN BOLT M6X60	8
0602.76	BACK COVER GASKET	1	6006.25	VALVE ASSY "PN" W/O O-RING ^{A E}	6
0605.09	GASKET D17X23X1.5 (G3/8)	1	6061.01	KIT 1 - VALVE KIT "PN/PW"	1
0605.33	GASKET D8X14X2 ^D	3	6061.08	KIT 8 - WATER SEAL KIT D18 "PN"	1
0605.49	GASKET D13X19X1.5	1	6061.14	KIT 14 - BRASS RING KIT D18 "PN"	1
0635.03	HIGH PRESS. SEAL ASSY D18 "PN" ^B	3	6061.20	Kit 20 - PLUNGER KIT D15/18 "PN"	1
1101.A2	O-RING - VALVE CAP	6			
1101.A3	O-RING - VALVE ^A	6			
1101.A4	O-RING - PLUNGER ^D	3			

^A Parts in 6061.01 (Kit 1)
^B Parts in 6061.04 (Kit 8)
^C Parts in 6061.14 (Kit 14)
^D Parts in 6061.20 (Kit 20)

*Dimensional Drawings are
Shown in Millimeters.
To Convert to Inches,
Multiply Dimension x 0.03937*

PN SERIES PUMPS - 3/4" HOLLOW SHAFT w/ HYDRAULIC MOTOR FLANGE

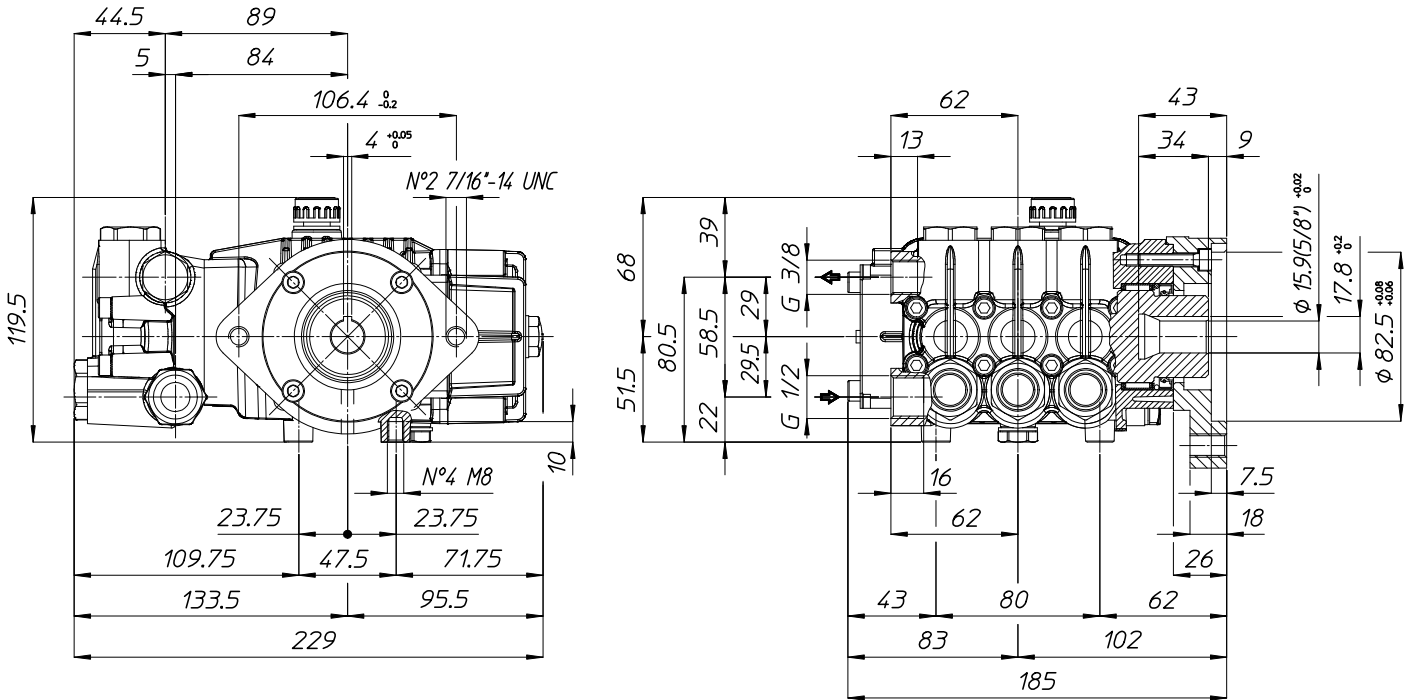

TORQUE SPECS

Ref.	Description	Ft./lb.	Nm	Loctite®
1	Head Bolts	8	11	-
2	Valve Caps	75	100	243
3	Inlet Cap	60	80	-
4	Outlet Cap	60	80	243
5	Bearing Flange Bolts	8	11	-
6	Rear Cover Bolts	8	11	-
7	Connecting Rod Bolts	-	-	-
8	Plunger Bolts	11	15	270
9	Valve Cover Bolts	-	-	-
10	Oil Drain Plug	6	8	-

