

OMEGA 140 TS2C

Maximum Flow	39.0 GPM / 148 lpm
Maximum Pressure	700 PSI / 48 bar
Maximum RPM	550 RPM
Inlet Port	1-1/2" Hose Barb
Outlet Ports	(2) 1/2" Hose Barb Valve, 3/4" FPT
Bypass	1" Hose Barb
Dimensions	17.5" L x 15" W x 16" H
Weight	100 lbs

Lubrication: Requires 87 oz. of Udor Lube 40W Premium Pump Oil.
Alternate Oil: 30W non-detergent or 15W-40 non-detergent oil.

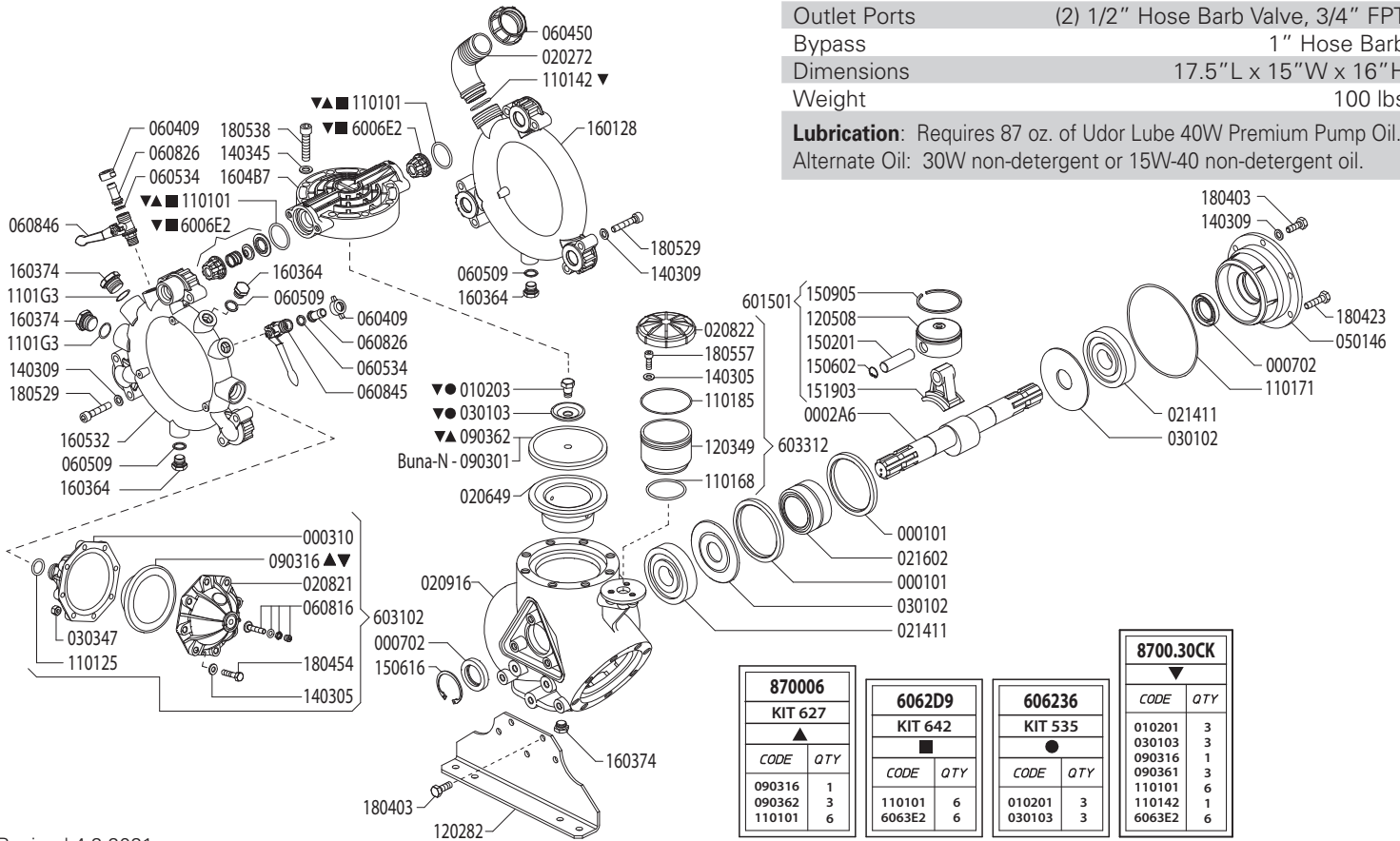

Revised 4-2-2021

Part #	Description	Qty
0001.01	RETAINER RING	2
0002.A6	SHAFT "ZETA 350/OMEGA" TS 2C	1
0003.10	PRESSURE ACCUMULATOR "BETA"	1
0007.02	SEAL	2
0102.01	DIAPHRAGM BOLT ●▼	3
0202.72	HOSE BARB D40	1
0206.49	PISTON SLEEVE	3
0208.21	ACCUMULATOR COVER "BETA"	1
0208.22	OIL RESERVOIR COVER "BETA"	1
0209.16	PUMP BODY	1
0214.11	BALL BEARING	2
0216.02	NEEDLE BEARING	1
0301.02	SPACER	2
0301.03	DIAPHRAGM WASHER ●	3
0303.47	HEX NUT M8X8	8
0501.46	BEARING FLANGE	1
0604.09	BRASS NUT G1/2	2
0604.50	BARB NUT	1
0605.09	ALUMINUM GASKET	2
0605.34	GASKET	2
0608.16	AIR VALVE ASSEMBLY	1
0608.26	1/2" BARB	2
0608.45	BALL VALVE RIGHT	1
0608.46	BALL VALVE LEFT	1
0903.01	PISTON DIAPHRAGM 130MM BUNA-N	3
0903.16	ACCUMULATOR DIAPHRAGM ▲▼	1
0903.62	PISTON DIAPHRAGM 130MM GREENTECH ▲▼	3
1101.01	O-RING - VALVE ■▲▼	6
1101.25	O-RING - ACCUMULATOR	1
1101.42	O-RING - INLET HOSE BARB▼	1
1101.68	O-RING - OIL RESERVOIR	1
1101.71	O-RING - BEARING FLANGE	1
1101.85	O-RING - OIL RESERVOIR	1
1101.G3	O-RING - PLUG	2
1202.82	MOUNTING RAIL	2
1203.49	OIL RESERVOIR "BETA"	1

Part #	Description	Qty
1205.08	ALUMINIUM PISTON D75 "BETA/OMEGA/ZETA"	3
1403.05	WASHER D8.4	3
1403.09	WASHER	16
1403.45	WASHER	24
1502.01	PIN D18X64	3
1506.02	SNAP RING D18	6
1506.16	SNAP RING D55	1
1509.05	PISTON RING D75	3
1519.03	CONNECTING ROD	3
1601.28	SUCTION MANIFOLD	1
1603.64	PLUG G3/8	3
1603.74	PLUG G3/4	3
1604.B7	PUMP HEAD	3
1605.32	DISCHARGE MANIFOLD	1
1804.03	HEX BOLT	8
1804.23	HEX BOLT	2
1804.54	HEX SCREW M8X35	8
1805.29	ALLEN BOLT M10X55	2
1805.38	ALLEN BOLT	24
1805.57	ALLEN BOLT M8X22	3
6006.E2	IN/OUT VALVE W/O O-RING ■▼	6
6015.01	PISTON ROD ASSEMBLY	3
6031.02	PRESSURE ACCUMULATOR ASSY "BETA"	1
6033.12	OIL RESERVOIR ASSEMBLY	1
6015.01	PISTON/ROD ASSEMBLY	3
6031.02	ACCUMULATOR ASSEMBLY	1
6033.02	OIL RESERVOIR ASSEMBLY	1
6062.36	DIAPHRAGM BOLT/WASHER KIT (KIT 535)	1
6062.D9	IN/OUT VALVE KIT (KIT 642)	1
8700.06	DIAPHRAGM KIT - GREENTECH (KIT 627)	1
8700.06CK	COMPLETE REPAIR KIT	1

- Parts in 6062.36 (Kit 515)
- Parts in 6062.D9 (Kit 642)
- ▲ Parts in 8700.06 (Kit 627)
- ▼ Parts in 8700.06CK (Complete Repair Kit)

6005.15 CONTROL UNIT

Maximum Flow	47.3 GPM / 179.2 lpm
Maximum Pressure	1200 PSI / 81 bar
Inlet Port	3/4" Male BSP
Outlet Ports	-
Bypass - Hose Barb	1" HB

606254	
KIT 553	
■	
CODE	QTY
090325	1
110101	1
110131	1
120413	1
150125	1
181001	1

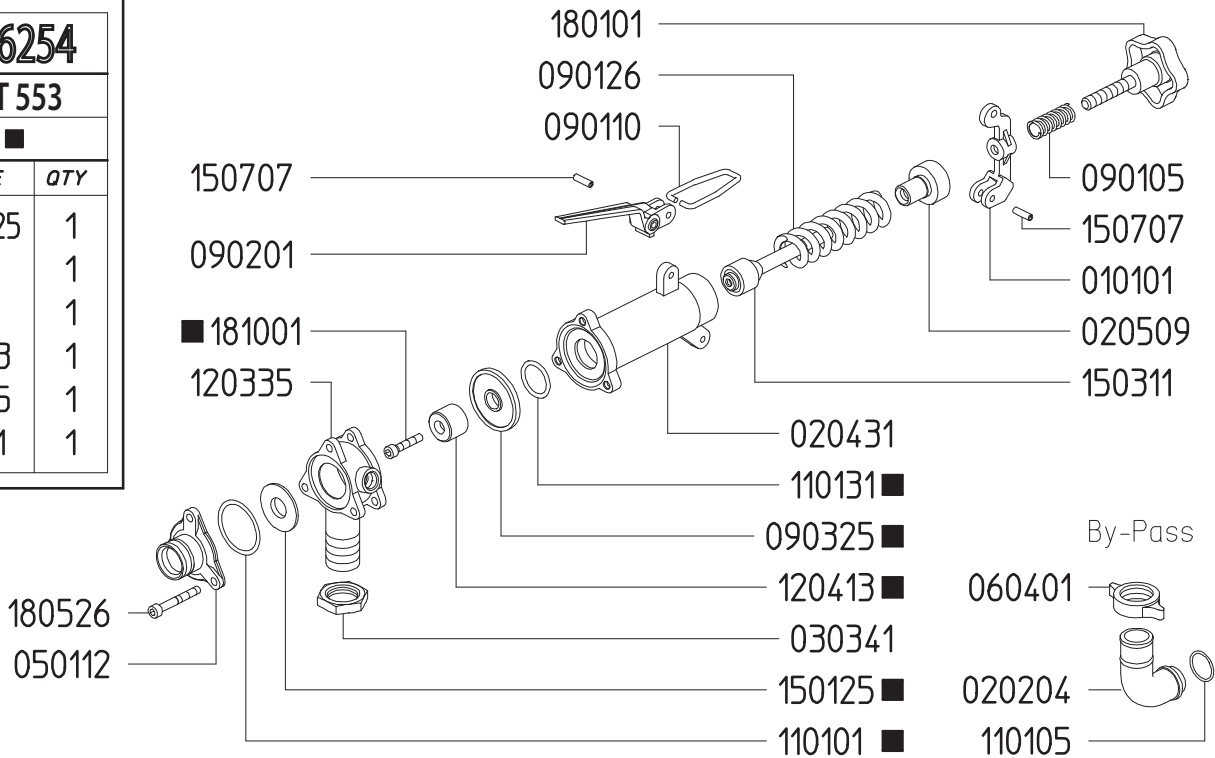

Revised 3-23-2021

Part #	Description	Qty
0101.01	LEVER GUIDE	1
0202.04	1" BRASS ELBOW HOSE BARB	1
0204.31	VALVE BODY	1
0205.09	VALVE CYLINDER	1
0303.41	NUT	1
0501.12	FLANGE	1
0604.01	BARB NUT	1
0901.05	SPRING	1
0901.10	PRESSURE BAIL	1
0901.26	SPRING	1
0902.01	HANDLE	1
0903.25 ■	DIAPHRAGM	1
1101.01 ■	O-RING	1
1101.05	O-RING	1

Part #	Description	Qty
1101.31 ■	O-RING	1
1203.35	INLET ELBOW - 3/4" MALE BSP	1
1204.13	POPPET ■	1
1501.25	SEAT ■	1
1503.11	REGULATOR STEM	1
1507.07	PIN	2
1801.01	ADJUSTMENT KNOB	1
1805.26	BOLT	3
1810.01	STAINLESS STEEL BOLT ■	1
GG1500	HIGH PRESSURE GAUGE (OPTIONAL)	1
6062.54	REPAIR KIT (KIT 553)	

■ Parts Included in Repair Kit #6062.54 (KIT 553)

OPERATING INSTRUCTIONS

1. Before operating or re-operating pump, lift R.V. Handle (0902.01) so pump will start at zero pressure.
FAILURE TO DO SO WILL VOID PUMP WARRANTY.
2. Turn Pressure Adjustment Knob (1801.01) counter-clockwise to relieve spring tension. (Step 2 is only necessary on initial start-up and is not necessary for daily operation.)
3. Start unit and let run until air is evacuated from system, when only liquid is expelled from the bypass line.
4. Return R.V. Handle (0902.01) to down position. Open spray gun or spray boom and turn adjustment knob (1801.01) clockwise until desired operating pressure is achieved.

OMEGA 140 DIMENSIONS

All Dimensions are WITHOUT Control Unit or Regulator

Dimensional Drawings are Shown in Millimeters. To Convert to Inches, Multiply Dimension x 0.03937

Specifications

OMEGA 140

Inlet Port - Hose Barb	1-1/2" HB
Outlet Ports - Hose Barb	(2) 3/4" FPT
Bypass - Hose Barb	1" HB
Dimensions	17.5" L x 15" W x 16" H
Diaphragm Material	GREENTECH (Std) Buna-N (Opt)

Lubrication: Requires 87 oz. of Udor Lube 40W Premium Pump Oil. Alternate Oil: 30W non-detergent or 15W-40 non-detergent oil.

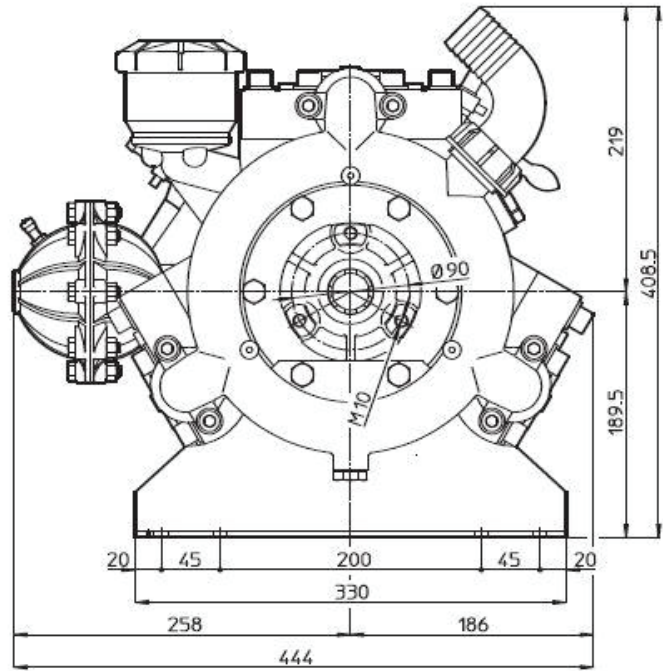
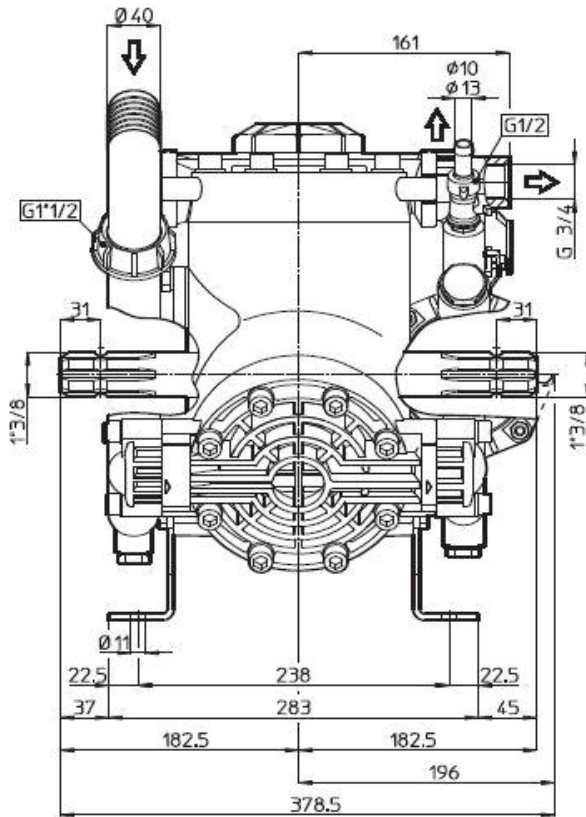

TORQUE SPECS

Ref.	Description	Ft./lb.	Nm
1	Diaphragm Bolts (Use Loctite 243)	22	30
2	Head Bolts	37	50
3	Pulsation Dampener Bolts	20	28
4	Bearing Flange Bolts	25	34
5	Oil Cup Bolts	7	10
6	Manifold Bolts - Aluminum/Brass	22	30

