

8700.26CK		870026 KIT 624		606246 KIT 545		606248 KIT 547	
CODE	QTY	CODE	QTY	CODE	QTY	CODE	QTY
010204	3	090308	1	110127	6	010204	3
030143	3	090315	3	606304	6	030143	3
090308	1	110127	6				
090315	3						
110127	6						
110141	1						
606304	6						

Maximum Flow	15.0 GPM
Maximum Pressure	560 PSI
Maximum RPM	550 RPM
Inlet Port - Hose Barb	1-1/4" HB
Outlet Ports - Hose Barb, Valve	(2) 1/2" HB
Bypass - Hose Barb	3/4" HB
Dimensions	9.5" L x 12.5" W x 10.5" H
Weight	37 lbs
Lubrication: Requires 23 oz. of Udor Lube 40W Premium Pump Oil. Alternate Oil: 30W non-detergent or 15W-40 non-detergent oil.	

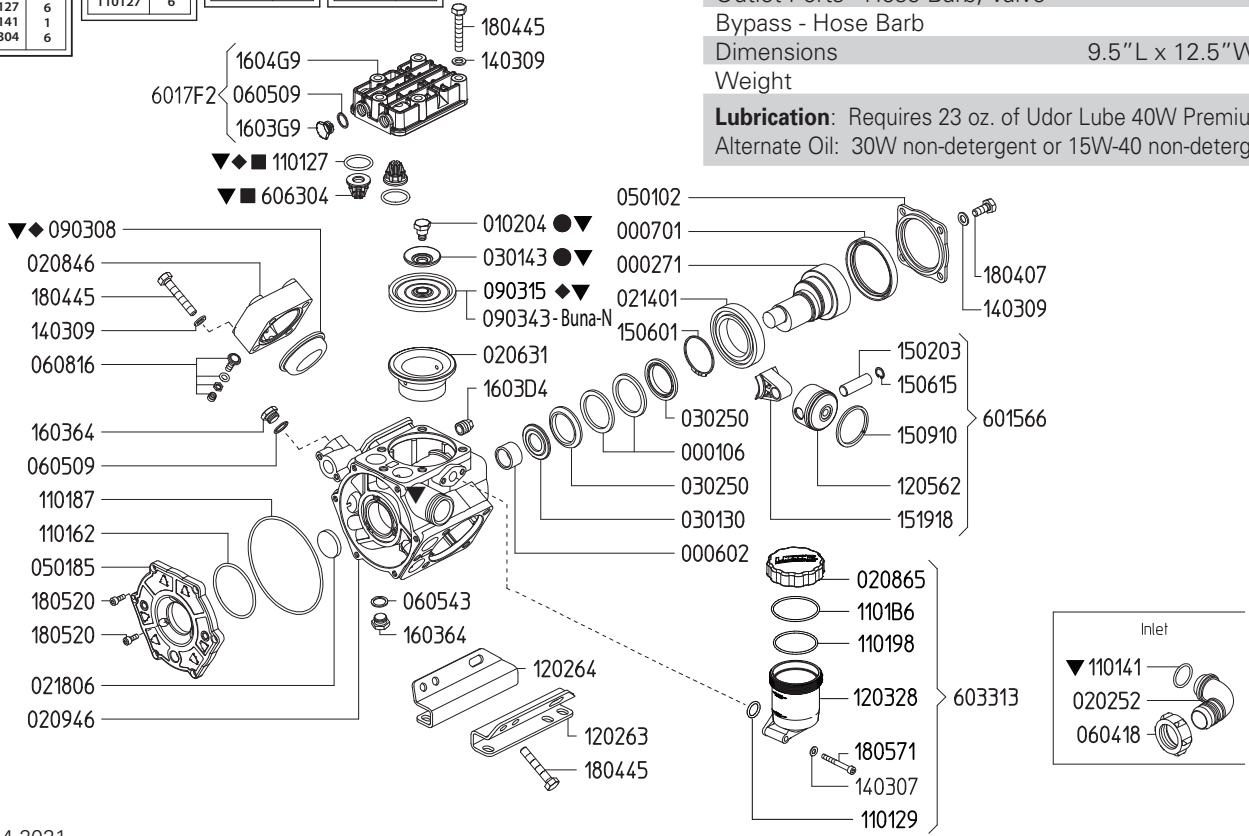

Revised 6-14-2021

Part #	Description	Qty	Part #	Description	Qty
0001.06	RETAINER RING	2	1202.63	RIGHT BASE PLATE	1
0002.71	SHAFT - VA	1	1202.64	LEFT BASE PLATE	1
0006.02	BUSHING D25	1	1203.28	OIL RESERVOIR	1
0007.01	OIL SEAL D78	1	1205.62	ALUMINIUM PISTON D55	3
0102.04	DIAPHRAGM BOLT ■▼	3	1403.07	WASHER D6.4	2
0202.52	HOSE BARB D32	1	1403.09	WASHER D10.5	19
0206.31	SLEEVE D55	3	1502.03	PIN D15X48	3
0208.46	ACCUMULATOR COVER	1	1506.01	SNAP RING D60	1
0208.65	OIL RESERVOIR COVER	1	1506.15	SNAP RING D15	3
0209.46	CRANKCASE - TS	1	1509.10	PISTON RING D55	3
0214.01	BALL BEARING D60	1	1519.18	CONNECTING ROD	3
0218.06	CAP D35X7	1	1603.64	PLUG G3/8	2
0301.30	BEARING DISC	1	1603.D4	PLUG G3/8	1
0301.43	DIAPHRAGM DISC ■▼	3	1603.G9	PLUG G3/8	6
0302.50	ROD SPACER	2	1604.G9	HEAD	3
0501.02	FLANGE	1	1804.07	HEX BOLT M10X25	4
0501.85	CRANKCASE FLANGE	1	1804.45	HEX BOLT M10X40	19
0604.18	BARB NUT M42X2	1	1805.20	ALLEN BOLT M6X16	9
0605.09	GASKET D17	7	1805.71	ALLEN BOLT M6X50	2
0605.43	GASKET D17	1	6015.66	ROD ASSEMBLY D55	3
0608.16	AIR VALVE ASSY	1	6017.F2	HEAD ASSEMBLY	3
0903.08	ACCUMULATOR DIAPHRAGM ◆▼	1	6033.13	OIL RESERVOIR ASSEMBLY	1
0903.15	PISTON DIAPHRAGM D90 - GREENTECH ◆▼	3	6063.04	VALVE ASSEMBLY W/O O-RING ●▼	6
0903.43	PISTON DIAPHRAGM D90 - BUNA-N	3	6062.46	IN/OUTLET VALVE KIT (KIT 545)	1
1101.27	O-RING - VALVE ●◆▼	6	6062.48	DIAPHRGM BOLT/WASHER (KIT 547)	1
1101.29	O-RING - OIL RESERVOIR	1	8700.26	DIAPHRAGM KIT - GREENTECH (KIT 624)	1
1101.41	O-RING - INLET HOSE BARB ▼	1	8700.26CK	COMPLETE REPAIR KIT	1
1101.62	O-RING - CRANKCASE FLANGE	1			
1101.87	O-RING - CRANKCASE FLANGE	1			
1101.98	O-RING - OIL RESERVOIR	1			
1101.B6	O-RING - OIL RESERVOIR	1			

- Parts in 6062.46 (Kit 545).
- Parts in 6062.48 (Kit 547).
- ◆ Parts in 8700.26 (Kit 624).
- ▼ Parts in 8700.26CK (Complete Repair Kit).

6010.24 & 6010.24/LP

Pump Mounted Control Unit

606253		606255	
KIT 552		KIT 554	
▲		■	
CODE	Q.TY	CODE	Q.TY
090326	1	090326	1
110104	1	110104	1
110112	2	110112	2
110141	1	110141	1
120419	1	150123	1
150123	1	870104	1
181001	1		

By-Pass

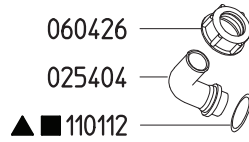

Outlet

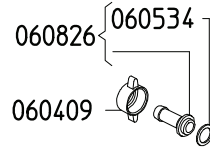

6010.24

Maximum Flow	27.0 GPM / 102 lpm
Maximum Pressure	560 PSI / 38 bar

6010.24/LP

Maximum Flow	27.0 GPM / 102 lpm
Maximum Pressure	350 PSI / 24 bar

Inlet Port - Hose Barb	-
Outlet Ports - Hose Barb, Valve	(2) 1/2" HB
Bypass - Hose Barb	3/4" HB

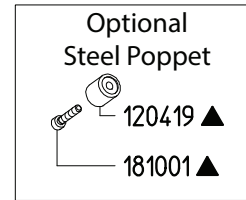
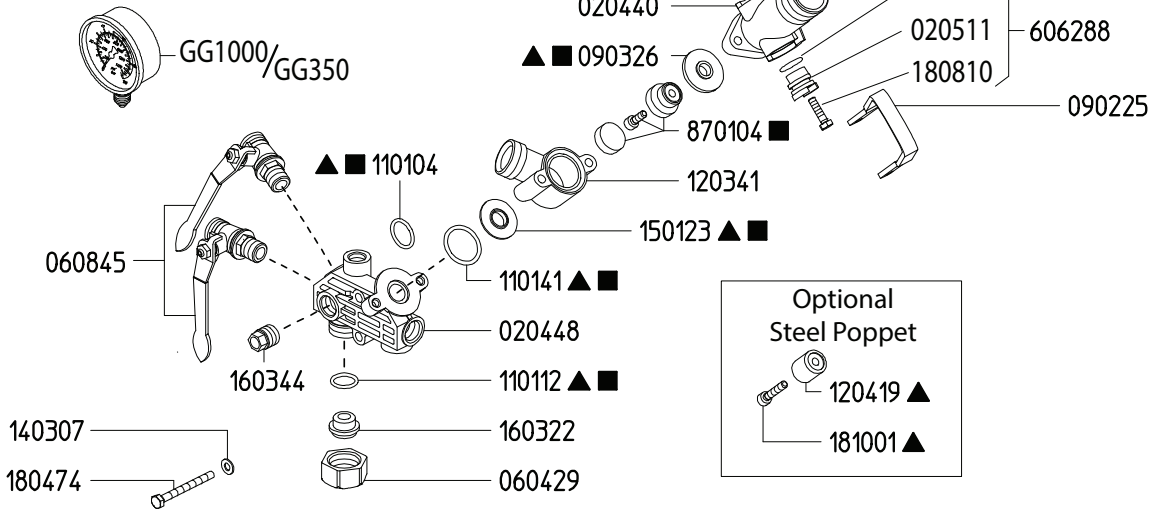

Revised 5-3-2021

Part #	Description	Qty
0202.25	BYPASS HOSE BARB - STRAIGHT (OPTIONAL)	1
0204.40	VALVE BODY	1
0204.48	MAIN BODY	1
0205.10	VALVE CYLINDER	1
0205.11	VALVE CYLINDER CAM	2
0254.04	BYPASS HOSE BARB - ELBOW	1
0604.09	DISCHARGE BARB NUT	2
0604.26	BYPASS BARB NUT	1
0604.29	BARB NUT	1
0605.34	GASKET	2
0608.26	1/2" HOSE BARB W/GASKET	2
0608.45	BALL VALVE; RIGHT	2
0901.24	HIGH PRESSURE SPRING "6010.24"	1
0901.47	LOW PRESSURE SPRING "6010.24/LP"	1
0902.25	DUMP VALVE LEVER	1
0903.26	DIAPHRAGM ▲■	1
1101.04	O-RING ▲■	1
1101.06	O-RING	2
1101.12	O-RING ▲■	2
1101.41	O-RING ▲■	1

Part #	Description	Qty
1203.33	BODY	1
1204.19	STEEL POPPET; "6010.24" ▲	1
1403.06	WASHER	1
1403.07	WASHER	4
1501.23	SEAT ▲■	1
1603.22	PLUG	1
1603.44	PLUG	2
1801.17	ADJUSTMENT KNOB	1
1804.74	BOLT	4
1808.10	BOLT	2
1810.01	STAINLESS STEEL BOLT; "6010.24" ▲	1
6062.88	REGULATOR CAM KIT	2
8701.04	URETHANE POPPET ASSEMBLY ■	1
GG1000	HIGH PRESSURE GAUGE - 1000 PSI "6010.24"	1
GG350	LOW PRESSURE GAUGE - 350 PSI "6010.24/LP"	1
6062.53	REPAIR KIT - 6010.24 (STEEL POPPET (KIT 552)	1
6062.55	REPAIR KIT - 6010.24/LP (KIT 554)	1

▲ Parts Included in Repair Kit 6062.53 (KIT 552)

■ Parts Included in Repair Kit 6062.55 (KIT 554)

1. Before operating or re-operating the pump, push the manual dump valve lever (0902.25) down, so the pump will start at zero pressure. FAILURE TO DO SO WILL VOID PUMP WARRANTY.
2. Turn pressure adjustment knob (1801.17) counterclockwise to relieve spring tension. NOTE: Step 2 applies only to initial start-up, and is not necessary in daily operation of pump.
3. Start unit and let run until air is evacuated from system, when only liquid is expelled from the bypass line.
4. Return dump valve lever to the UP position. Open spray gun or spray boom and turn the pressure adjustment knob (1801.17) clockwise until desired operating pressure is achieved.

All Dimensions are WITHOUT Control Unit or Regulator

Dimensional Drawings are Shown in Millimeters. To Convert to Inches, Multiply Dimension x 0.03937

Specifications

KAPPA 55

Inlet Port - Hose Barb	1-1/4" HB
Outlet Ports - Hose Barb	(2) 1/2" HB
Bypass - Hose Barb	3/4" HB
Dimensions	9.5" L x 12.5" W x 10.5" H
Diaphragm Material	GREENTECH (Std) Buna-N (Opt)

Lubrication: Requires 23 oz. of Udor Lube 40W Premium Pump Oil. Alternate Oil: 30W non-detergent or 15W-40 non-detergent oil.

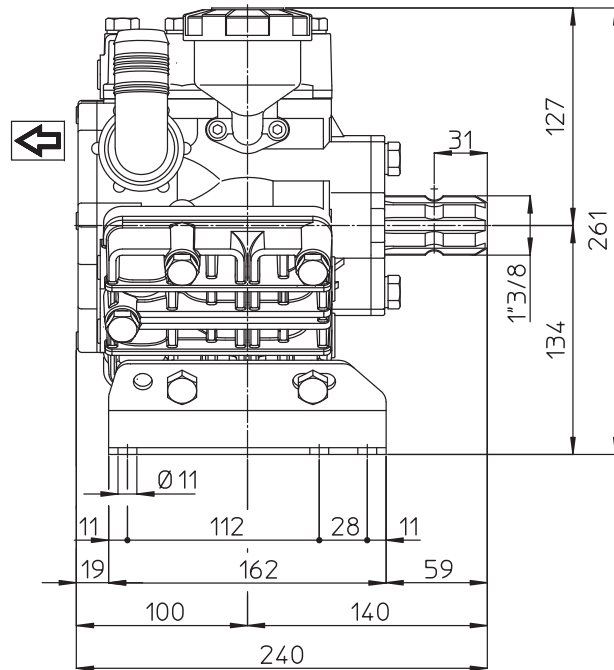
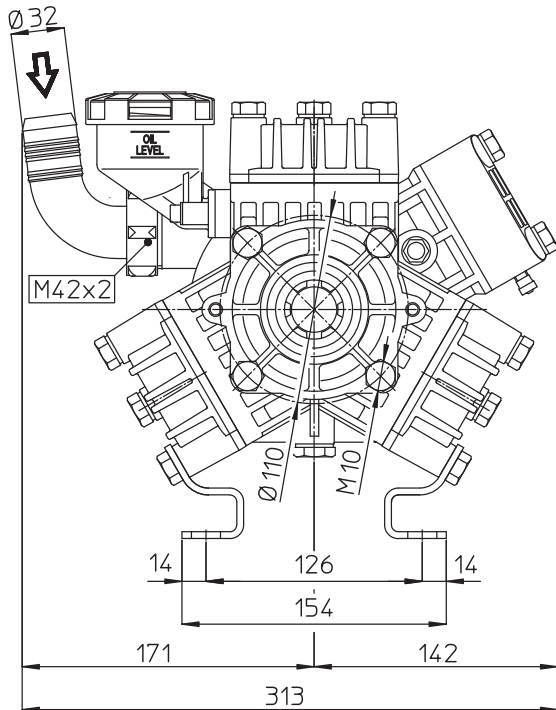

TORQUE SPECS

Ref.	Description	Ft./lb.	Nm
1	Diaphragm Bolts (Use Loctite 243)	18	25
2	Head Bolts	30	40
3	Pulsation Dampener Bolts	30	40
4	Inlet Flange Bolts	7	10
5	Bearing Flange Bolts	25	34
6	Oil Cup Bolts	6	8
7	Valve Cover Bolts	N/A	N/A

