

WARNING! UDOR Plunger Pumps are positive displacement pumps, therefore a properly designed pressure relief valve or unloader valve must be installed on the pump or in the discharge plumbing. A secondary safety relief valve is also recommended. Failure to install a pressure relief valve or unloader valve could result in personal injury, property damage or damage to the pump or system and void any warranty. In no way does UDOR USA assume any liability or responsibility for the construction or operation of a customer's or potential customer's high pressure system.

LOCATION: If the pump is used in dirty or humid conditions, it is recommended that the pump be enclosed. Do not store or operate in excessively high temperature areas or without proper ventilation.

MOUNT: Mount the pump on a rigid, horizontal surface in such a way as to permit drainage of crankcase. An uneven mounting surface will cause damage to the pump. Use appropriate flexible hose to the inlet and discharge ports. Use the proper belts, making sure pulleys are aligned. Excessive belt tension can be harmful to bearings. For CK-Series gear reduction applications, pump must have support rail with vibration isolators or an UDOR torque plate installed. Contact UDOR U.S.A. for information.

PUMP ROTATION: UDOR Plunger Pumps are designed for forward rotation to allow optimum lubrication of the crosshead area. Reverse rotation is acceptable if the crankcase oil level is increased slightly above the center dot to assure proper lubrication.

PUMP SPEED: Do not over speed the pump. UDOR Plunger Pumps are designed to operate at or below a specific RPM. Over speeding will cause valves and seals to prematurely fail and could cause other internal damage. Refer to the performance chart or breakdown of your specific pump for maximum operating RPM

LUBRICATION: Fill the crankcase with UDOR LUBE Premium Pump Oil or SAE 30W non-detergent oil per pump specifications. DO NOT run pump without oil in crankcase. Change oil after initial 50 hour break-in and every 500 hours or 3 months there-after. For any pump with a gear reduction, make sure the gear box is filled to the center of the sight glass with 90 wt. gear lube before operating.

PUMPED FLUIDS: Some fluids may require a flush between operations or before storing. For information regarding pumping fluids other than water, please contact UDOR U.S.A.

INLET CONDITIONS: Ensure proper inlet flow. DO NOT STARVE THE PUMP OR RUN PUMP DRY!

DISCHARGE PLUMBING: DO NOT START PUMP UNLESS A PRESSURE RELIEF VALVE OR UNLOADER VALVE IS INSTALLED. OPEN ALL VALVES BEFORE STARTING THE SYSTEM TO AVOID DEADHEAD OVERPRESSURE CONDITION AND SEVERE DAMAGE TO THE PUMP OR SYSTEM.

PULSATION DAMPENERS: (Optional) Install dampener directly into discharge line. Make sure the pulsation dampener is properly pre-charged for the system pressure.

PRESSURE GAUGE: Install pressure gauge near the discharge outlet of the high pressure manifold or in the discharge plumbing. This is extremely important for adjusting the pressure relief valve / unloader valve and for proper sizing of the nozzle or restricting orifice. The pump is rated for a maximum pressure, which should be read at the discharge manifold of the pump only, not at the gun or nozzle.

PRESSURE RELIEF VALVE/UNLOADER VALVE: A pressure relief valve or unloader valve must be installed to prevent over pressurizing and severely damaging the pump if the discharge is turned off or becomes plugged. Pressure relief valves / unloader valves should be at minimum pressure setting at start-up. On any high pressure system, secondary protection, such as a pop-off valve or safety valve, is recommended. Start system with all valves open or in the low pressure setting.

CAUTION: FAILURE TO INSTALL A PRESSURE RELIEF VALVE OR UNLOADER VALVE WILL VOID THE WARRANTY ON THE PUMP.

NOZZLES: A worn nozzle will result in loss of pressure. Do not adjust the pressure relief valve / unloader valve to compensate for pressure loss. Replace nozzle and reset the pressure relief valve / unloader valve to proper system pressure.

STORING: For extended storage or between use in cold climates, drain all pumped fluids from the pump and complete system and flush with a 50/50 mixture of anti-freeze and water to prevent freezing and damage to the pump. DO NOT run pump with frozen fluid. Before restarting the pump after anti-freezing, make sure to purge all anti-freeze from pump and complete system at low pressure only. Anti-freeze will foam under high pressure and can cause severe damage to the pump and pressure regulator. FAILURE TO FOLLOW THIS STEP WILL VOID ANY AND ALL WARRANTIES.

UDOR USA BASIC PRESSURE FEED HIGH PRESSURE CLEANING SYSTEM PLUMBING DIAGRAM

NOTE: This is a basic pressure feed plumbing diagram and is not recommended for all systems. Consult UDOR USA for specific system requirements and components.

On any multiple gun system never use a standard unloader style valve; these valves are designed for full on or full off only. A balance relief valve must be used for multiple gun systems.

Use blue threadlocker or equivalent on all plumbing components, fittings and accessories.

WARNING! DO NOT PUMP OR FLUSH PUMP WITH ANY FLAMMABLE, EXPLOSIVE, CAUSTIC OR CORROSIVE FLUIDS. DO NOT USE ANY OF THESE PRODUCTS IN AN EXPLOSIVE ATMOSPHERE. FAILURE TO FOLLOW THIS WARNING CAN RESULT IN PERSONAL INJURY OR PROPERTY DAMAGE AND WILL VOID ANY AND ALL WARRANTIES.

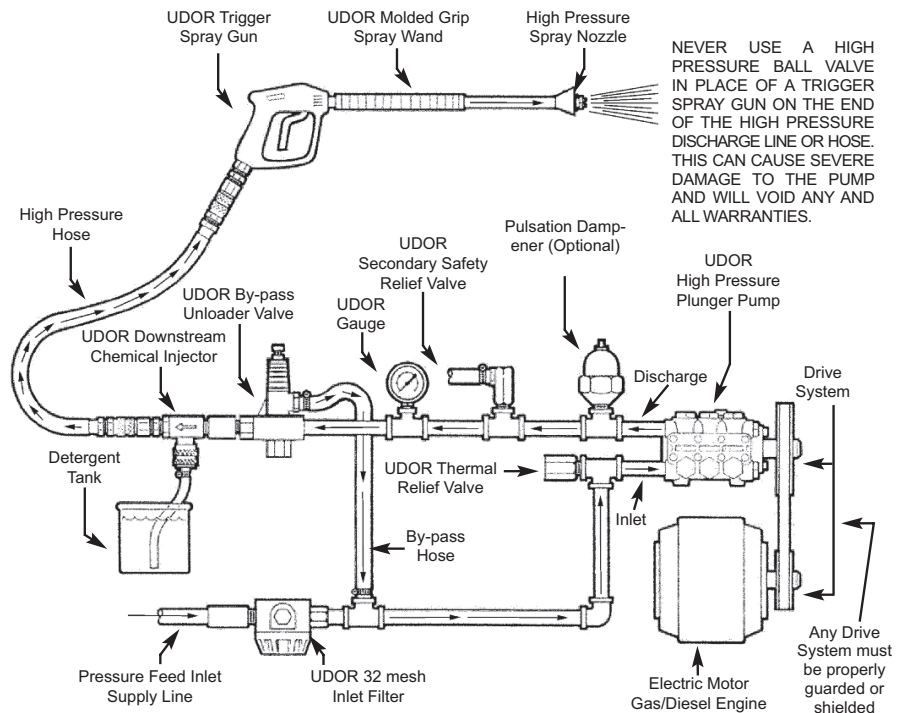

BASIC PLUNGER PUMP TANK FEED HIGH PRESSURE CLEANING SYSTEM PLUMBING DIAGRAMS

These are basic tank feed plumbing diagrams and are not recommended for all systems. Consult UDOR USA for specific system requirements and components.

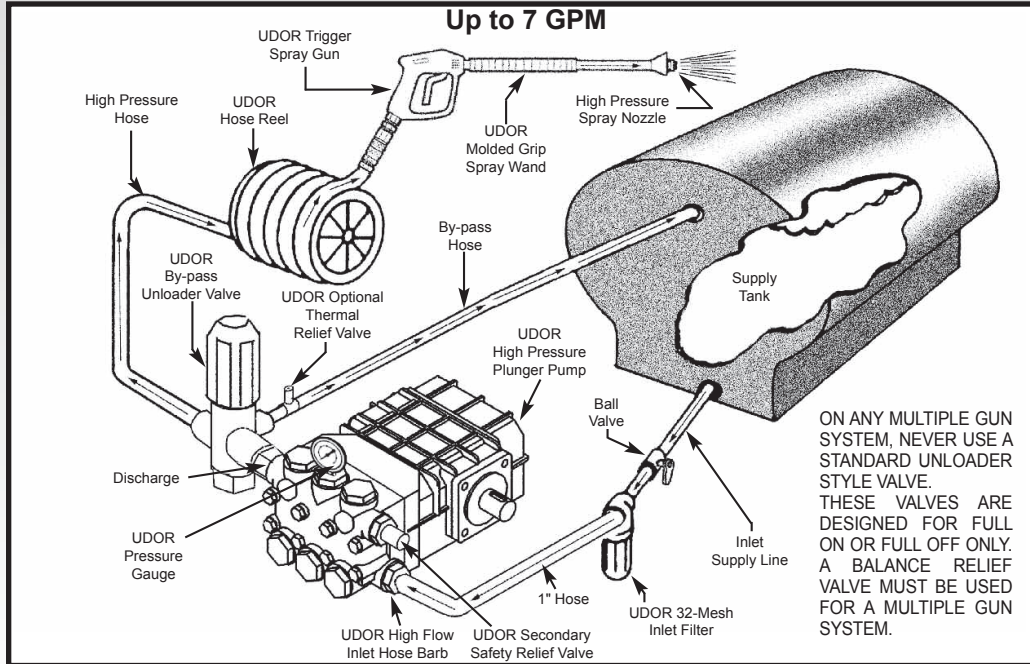

NOTE: On any tank feed system each pump must be fed by its own separate feed line only. Never feed multiple pumps with one common feed line.

FEED TANK SIZE: A recommended minimum feed tank size is 6-10 times the maximum GPM output rating of the pump or pumps being used.

SAMPLE: 10 GPM PUMP x 6= 60 GALLON MINIMUM FEED TANK SIZE.

MAKE SURE ALL FEED TANKS HAVE PROPER BAFFLES AND VENTING.

USE BLUE THREADLOCKER OR EQUIVALENT ON ALL PLUMBING COMPONENTS, FITTINGS AND ACCESSORIES.

NEVER USE A HIGH PRESSURE BALL VALVE IN PLACE OF A TRIGGER SPRAY GUN ON THE END OF THE HIGH PRESSURE DISCHARGE LINE OR HOSE. THIS CAN CAUSE SEVERE DAMAGE TO THE PUMP AND WILL VOID ANY AND ALL WARRANTIES.

Always keep the by-pass line as far away as possible from the inlet supply line to prevent aeration or cavitation of the fluid being pumped.

MINIMUM PLUMBING REQUIREMENTS	Pump GPM	Min. Feed Line Size	Inlet Filter (40 Mesh Max.)	NOTE: All plumbing accessories should be the same or greater diameter as the feed line. All ball valves should be full port valves only.
	2 - 4 GPM	3/4"	3/4" 20-40 Mesh Screen	
	5 - 7 GPM	1"	1" 20-40 Mesh Screen	
	8 - 19 GPM	1-1/4"	1-1/4" 20-40 Mesh Screen	
	20 - 30 GPM	1-1/2"	1-1/2" 20-40 Mesh Screen	

WARNING: Consult UDOR U.S.A. for plumbing requirements on high speed, 3400 RPM Direct Drive Pumps.

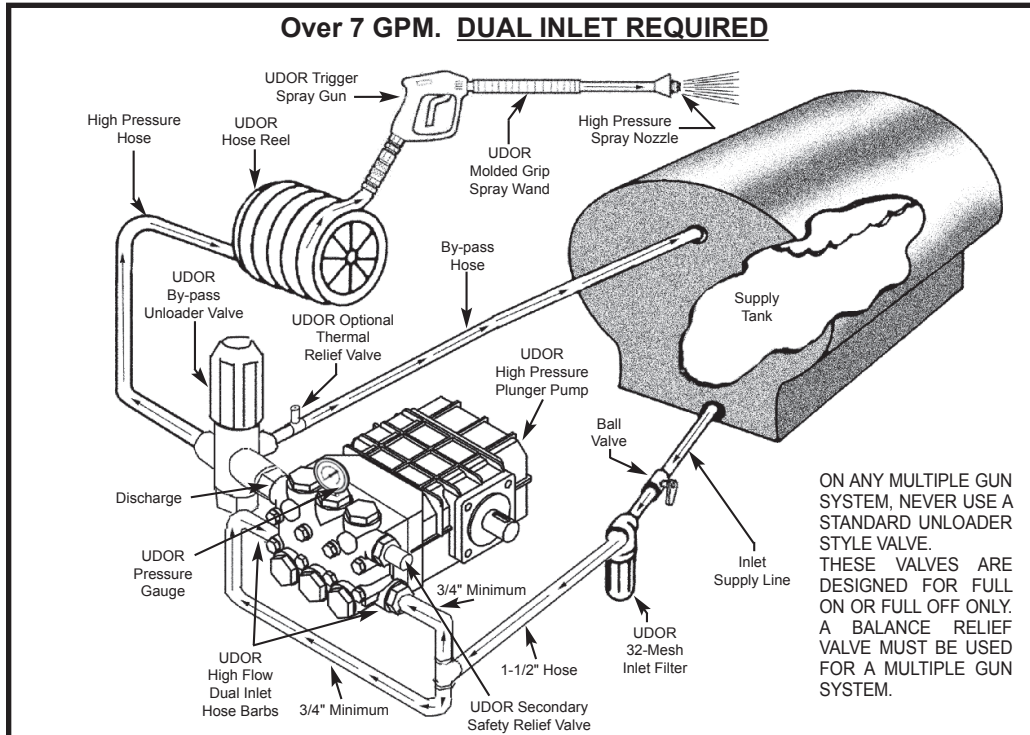

NOTE: On any tank feed system each pump must be fed by its own separate feed line only. Never feed multiple pumps with one common feed line.

NOTE: For Tank Feed Systems over 7 GPM, feed pumps through BOTH inlets to ensure proper flow and prevent cavitation and damage to the pump.

FEED TANK SIZE: A recommended minimum feed tank size is 6-10 times the maximum GPM output rating of the pump or pumps being used.

SAMPLE: 10 GPM PUMP x 6= 60 GALLON MINIMUM FEED TANK SIZE.

MAKE SURE ALL FEED TANKS HAVE PROPER BAFFLES AND VENTING.

USE BLUE THREADLOCKER OR EQUIVALENT ON ALL PLUMBING COMPONENTS, FITTINGS AND ACCESSORIES.

NEVER USE A HIGH PRESSURE BALL VALVE IN PLACE OF A TRIGGER SPRAY GUN ON THE END OF THE HIGH PRESSURE DISCHARGE LINE OR HOSE. THIS CAN CAUSE SEVERE DAMAGE TO THE PUMP AND WILL VOID ANY AND ALL WARRANTIES.

Always keep the by-pass line as far away as possible from the inlet supply line to prevent aeration or cavitation of the fluid being pumped.